

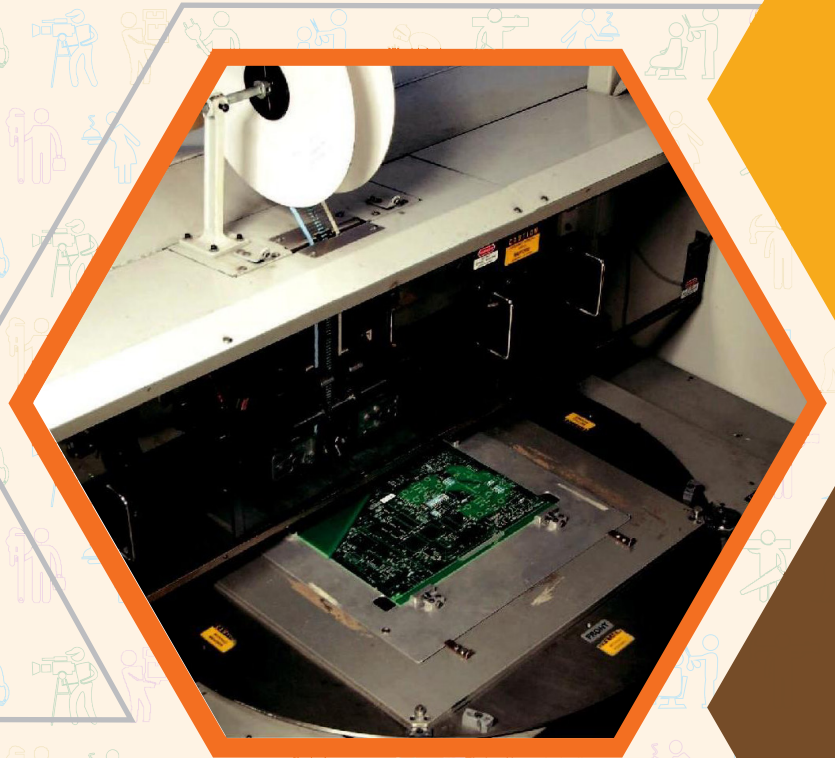
Participant Handbook

Sector
Electronics

Sub- Sector
Electronics Manufacturing System

Occupation
Assembly and Soldering

Reference ID: **ELE/Q5101, Version 2.0**
NSQF Level 4



Through-Hole Assembly Operator

Published by

Electronics Sector Skills Council of India (ESSCI)

155, 2nd Floor, ESC House, Okhla Industrial Area, Phase 3, New Delhi - 110020, India

Email : info@essc-india.org

Website: www.essc-india.org

Phone: +91 11 46035050, +91 8447738501

All Rights Reserved©2022

First Edition, July 2022

Copyright©2022

Electronics Sector Skills Council of India (ESSCI)

155, 2nd Floor, ESC House, Okhla Industrial Area, Phase 3, New Delhi - 110020, India

Email : info@essc-india.org

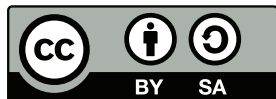
Website: www.essc-india.org

Phone: +91 11 46035050, +91 8447738501

This book is sponsored by Electronics Sector Skills Council of India (ESSCI)

Under Creative Commons Licence: CC-BY-SA

Attribution-ShareAlike: CC BY-SA



This license lets others remix, tweak, and build upon your work even for commercial purposes, as long as they credit you and license their new creations under the identical terms. This license is often compared to “copyleft” free and open-source software licenses. All new works based on yours will carry the same license, so any derivatives will also allow commercial use. This is the license used by Wikipedia and is recommended for materials that would benefit from incorporating content from Wikipedia and similarly licensed projects.

Disclaimer

The information contained here in has been obtained from sources reliable to ESSCI. ESSCI disclaims all warranties to the accuracy, completeness or adequacy of such information. ESSCI shall have no liability for errors, omissions, or inadequacies, in the information contained herein, or for interpretations thereof. Every effort has been made to trace the owners of the copyright material included in the book. The publishers would be grateful for any omissions brought to their notice for acknowledgements in future editions of the book. No entity in ESSCI shall be responsible for any loss whatsoever, sustained by any person who relies on this material. The material in this publication is copyrighted. No parts of this publication may be reproduced, stored or distributed in any form or by any means either on paper or electronic media, unless authorized by the ESSCI.





Shri Narendra Modi
Prime Minister of India

“ Skilling is building a better India.
If we have to move India towards
development then Skill Development
should be our mission. ”



Certificate

**COMPLIANCE TO
QUALIFICATION PACK – NATIONAL OCCUPATIONAL
STANDARDS**

is hereby issued by the

ELECTRONICS SECTOR SKILLS COUNCIL OF INDIA

for

SKILLING CONTENT : PARTICIPANT HANDBOOK

Complying to National Occupational Standards of

Job Role/Qualification Pack **"Through-Hole Assembly Operator" QP No."ELE/Q5101,**
NSQF Level 4"

Date of Issuance: 24.02.2022

Valid up to*: 02.06.2025

*Valid up to the next review date of the Qualification Pack or the
'Valid up to' date mentioned above (whichever is earlier)

Authorized Signatory
Electronics Sector Skills Council of India

Acknowledgments

This participant's handbook meant for Through-Hole Assembly Operator is a sincere attempt to ensure the availability of all the relevant information to the existing and prospective job holders in this job role. We have compiled the content with inputs from the relevant Subject Matter Experts (SMEs) and industry members to ensure it is the latest and authentic. We express our sincere gratitude to all the SMEs and industry members who have made invaluable contributions to the completion of this participant's handbook.

I would like to thank the SME and the team at the ESSCI along with the industry partners for the tireless effort in bringing the handbook in the current format.

This handbook will help deliver skill-based training in the field of Through-Hole Assembly. We hope that it will benefit all the stakeholders, such as participants, trainers, and evaluators. We have made all efforts to ensure the publication meets the current quality standards for the successful delivery of QP/NOS-based training programs. We welcome and appreciate any suggestions for future improvements to this hand book.

ABOUT THIS BOOK

This participant handbook has been designed to serve as a guide for participants who aim to obtain the required knowledge and skills to undertake various activities as a **Through-Hole Assembly Operator**. Its content has been aligned with the latest Qualification Pack (QP) prepared for the job role. With a qualified trainer’s guidance, the participants will be equipped with the following for working efficiently in the job role:

- Knowledge and Understanding: The relevant electrical assembly & soldering knowledge and understanding to perform the assembling & soldering PCB tasks.
- Performance Criteria: The essential skills through hands-on training to perform the electrical assembling & soldering operations to the applicable quality standards.
- Professional Skills: The Ability to make appropriate assembling & soldering decisions about the electrical PCB assembly & soldering work.

The handbook details the relevant activities to be carried out by a **Through-Hole Assembly Operator**. After studying this handbook, job holders will be adequately skilled to carry out their duties efficiently according to the applicable quality standards, with minimum supervision.

The handbook has been divided into an appropriate number of units and sub-units based on the content of the relevant QP. We hope it will facilitate easy and structured learning for the participants. We sincerely hope that participants will obtain enhanced knowledge and skills after studying this handbook and make career progress in the relevant and senior job roles.

The Participant Handbook is designed based on the National Skill Qualification Framework (NSQF) aligned Qualification Pack (QP) and it comprises of the following National Occupation Standards (NOS)/ topics:

- ELE/N5101 - Perform through-hole assembly on PCB components
- ELE/N9905 – Work effectively at the workplace
- ELE/N1002 – Apply health and safety practices at the workplace
- Employability & Entrepreneurship Skills

Symbols Used



Key Learning
Outcomes



Exercise



Steps



Tips



Notes



Unit
Objectives

Table of Contents

S. No	Modules and Units	Page No.
1.	Introduction and orientation to the role of a Through-Hole Assembly Operator	1
	Unit 1.1 Size and scope of the electronics industry and its various sub- sectors	3
	Unit 1.2 Opportunities for Through-Hole Assembly Operator in the industry.	7
	Unit 1.3 Roles and responsibilities of a Through-Hole Assembly Operator	8
2.	Process of performing through-hole assembly on PCB components (ELE/N5101)	13
	Unit 2.1 Manual mounting & placement of components	15
	Unit 2.2 SOP for bending leads & mounting	28
	Unit 2.3 Soldering	38
	Unit 2.4 Daily maintenance & Documentation	48
3.	Work effectively at the workplace (ELE/N9905)	55
	Unit 3.1 Effective Communication and Coordination of work	57
	Unit 3.2 Work effectively and Maintaining discipline at work.	64
	Unit 3.3 Maintaining social diversity at work	75
4.	Apply health and safety practices at the workplace (ELE/N1002)	83
	Unit 4.1 Workplace Hazards	85
	Unit 4.2 Fire Safety	97
	Unit 4.3 First Aid	101
	Unit 4.4 Waste Management	105
5.	Employability &Entrepreneurship Skills	111
	Unit 5.1 Personal Strengths & Value Systems	115
	Unit 5.2 Digital Literacy: A Recap	134
	Unit 5.3 Money Matters	140
	Unit 5.4 Preparing for Employment & Self Employment	151
	Unit 5.5 Understanding Entrepreneurship	160
	Unit 5.6 Preparing to be an Entrepreneur	182



1. Introduction and orientation to the role of a Through-Hole Assembly Operator



- Unit 1.1 Size and scope of the electronics industry and its various sub- sectors
- Unit 1.2 Opportunities for Through-Hole Assembly Operator in the industry.
- Unit 1.3 Roles and responsibilities of a Through-Hole Assembly Operator



Key Learning Outcomes

By the end of this module, participants will be able to:

- Describe the size and scope of the electronic industry and its subsectors.
- Discuss the role and responsibilities of a Through-Hole Assembly Operator.
- Describe various employment opportunities for a Through-Hole Assembly Operator.

Unit 1.1 Size and scope of the electronics industry and its various sub-sectors

Unit Objectives

By the end of this unit, participants will be able to:

1. Describe the size and scope of the Electronics industry.
2. Identify the sub-sectors of the Electronics industry.

1.1 Describe the size and scope of the electronics industry and its various sub- sectors

The Indian Electronics System Design & Manufacturing (ESDM) industry is one of the vital sectors of the Indian economy. The country has witnessed a substantial spike in demand for electronic products in the last few years. Today, India is positioned as the second-largest mobile phone manufacturer globally, with a surging internet penetration rate.

The ESDM sector is playing a vital role in the Indian government's goal of generating US\$ 1 trillion of economic value from the digital economy by 2025. With several government initiatives aiming to boost domestic manufacturing, India is witnessing increased production and assembly activities across products, such as consumer electronics and mobile phones.

Market Size

- The Indian electronics manufacturing industry is projected to reach US\$ 520 billion by 2025.
- In FY22 (until October 2021), imports of electronics goods stood at US\$ 28.59 billion, whereas exports stood at US\$ 7.89 billion.
- The demand for electronic products is expected to rise to US\$ 400 billion by 2025 from US\$ 33 billion in Fy20.
- The electronics market has witnessed a growth in demand, with market size increasing from US\$ 145 billion in FY16 to US\$ 215 billion in FY19—the market witnessed a growth of 14% CAGR from 2016-19.
- India's exports of electronic goods were valued at US\$ 11.7 billion in FY21.
- Smartphone shipments in India increased by ~82% YoY to reach 33.0 million units in the second quarter of 2021.
- The Electronics System Design & Manufacturing (ESDM) is broadly segregated into—electronics system and electronics design.
- The electronics system market is expected to witness 2.3x demand of its current size (FY19) to reach US\$ 160 billion by FY25.
- Electronics design segment, growing at 20.1%, was 22% of the ESDM market size in FY19; it is anticipated to be 27% of the ESDM market size in FY25.
- India's consumer electronics and appliances industry is expected to become the 5th largest globally by 2025.
- According to the Department for Promotion of Industry and Internal Trade, from April 2000 to June 2021, Foreign Direct Investment (FDI) equity inflows stood at US\$ 3,176.29 million.

1.1.2 Sub-Sectors of the Electronics System Design & Manufacturing (ESDM) Industry

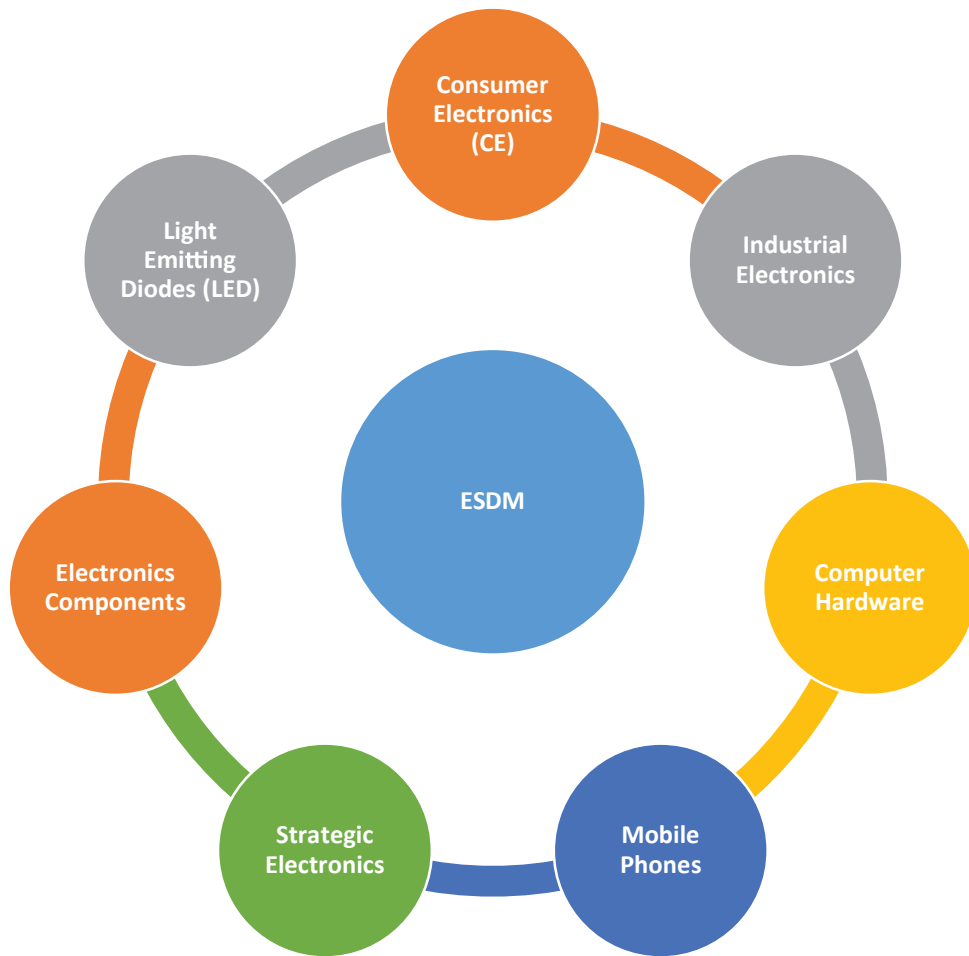


Fig. 1.1.1 Sub-sectors of the Electronics System Design & Manufacturing (ESDM) Industry

Notes



A large rectangular area enclosed by an orange border, containing 20 horizontal lines for writing notes.

Unit 1.2 Opportunities for Through-Hole Assembly Operator in the industry

Unit Objectives

By the end of this unit, participants will be able to:

1. Scope of Through-Hole Assembly Operator in the electronic industry

1.2.1 Career Pathways of Through-Hole Assembly Operator

There are different career pathways that a Through-Hole Assembly Operator can take. Following are some of them:

- Lateral movement in the electronic industry or other related sectors where electrical appliances are used. The individual can work as an employee with such a company.
- With appropriate knowledge and adequate years of experience, the individual may also become a senior assembler PCB.
- Later, the individual may become a Supervisor and even progress to a manager's level.
- The person can even work as an entrepreneur and start own service centre.
- Similarly, with strong technical expertise, one can even become a trainer at a training institute or start own training centre.

1.2.2 Personal Attributes of a Through-Hole Assembly Operator

A Through-Hole Assembly Operator needs to have some essential personal attributes for performing various activities effectively. The individual should have attention to detail and problem-solving skills to quickly identify any malfunctioning or problems with electrical components for their timely resolution. The person should have logical thinking to analyze a situation/problem logically to find an appropriate solution and appropriate technical expertise to perform repair and maintenance activities efficiently. Good decision-making skills are also important for the individual to ensure the correct decision is taken concerning the corrective measures to be taken for PCB repair.

The person usually caters to clients who experience issues with their electric appliances. For this reason, the individual needs to have good client-dealing skills and the ability to work as per their requirement. It also includes effective communication skills, i.e. talking courteously and listening attentively.

In a dynamic technological environment, it is also vital for the individual to stay updated with the latest developments in the field of work by reading the relevant literature and staying in contact with relevant persons.

Unit 1.3 Roles and responsibilities of a Through-Hole Assembly Operator

Unit Objectives

By the end of this unit, participants will be able to:

1. Understand the duties of Through-Hole Assembly Operator

1.3.1 Job Description: Through-Hole Assembly Operator

The tasks a Through Hole Assembly Operator is expected to perform include:

- Collecting the desired components from stores as per design chart
- Mounting the components on the board
- Soldering the components
- Performing visual quality check on the soldered PCB
- Following the standard safety procedures

Key Competencies

- Knowledge of various components used in the PCBs
- Well-versed with IPC standards
- Adept with the basic characteristics of the components like resistor, capacitor, etc.
- Proficient in reading the design charts
- Proficient in comparing between ROHS & non-ROHS complaint solder
- Knowledge of solder machine operation and types of solder paste
- Well-versed with hand soldering technique, soldering phenomena, handling the soldering iron, iron temperature, etc.
- Adept in the basics of wave soldering such as flux and their types, pre-heat conditions, wave profile, etc.
- Knowledge of zero defect soldering, lead cutting and component lifting
- Well-versed with Electro Static Discharge (ESD) requirements and devices

1.3.2 In addition, the individual has the following responsibilities:

- Communicating effectively at the workplace.
- Working effectively.
- Maintaining and enhancing professional competence.
- Working in a disciplined and ethical manner.
- Upholding social diversity in the workplace.
- Dealing with workplace hazards.
- Following fire safety practices.
- Following emergencies, rescue and first-aid procedures.
- Following effective waste management/recycling practices.

Electrical equipment industry facing skilled manpower problem

- It said that the electrical equipment industry is facing a major problem in getting skilled and employable manpower which is technically competent, equipped with skills and ready to be deployed.
- “The industry is facing a looming skill gap, which is widening every year. Due to lack of skilled manpower, electrical equipment industry is suffering as it is affecting critical functions like R&D, consultancy, design and detailed engineering work,” it added.
- The technical education system in the country does not promote innovative thinking, it said adding training being provided in the ITIs is out dated and the students are not able to meet the aspirations of the industry.
- “Even the qualified supervisors and engineers are not available. Those who are qualified are not well trained to meet the technical needs of the industry. Because of the above factors the labour productivity in India is far less than the labour productivity in China and Korea,” the statement said.
- It said that this is one of the important reasons for making the industry non-competitive and is also affecting the timely completion of the projects.
- The ministry said that there is an urgent need for training the work force for all the segments of the industry and making changes in the curriculum of the polytechnics and engineering colleges.

EXERCISE

Short Questions

1. Explain the importance of the electronics industry.
2. Write about Through Hole Assembly Operator.
3. Explain briefly the problems faced by electronics industry.

Long Questions

1. Describe the size and scope of the electronics industry and its various sub- sectors.
2. Discuss the various opportunities for a Through Hole Assembly Operator in the electronics industry.
3. Discuss the role and responsibilities of a Through Hole Assembly Operator.

Notes



Notes



A large rectangular area enclosed in an orange border, containing 21 horizontal lines for writing notes.



2. Process of performing through-hole assembly on PCB components

- Unit 2.1 Manual mounting & placement of components
- Unit 2.2 SOP for bending leads & mounting
- Unit 2.3 Soldering
- Unit 2.4 Daily maintenance & Documentation



Key Learning Outcomes

By the end of this module, participants will be able to:

- List the procedure for manual mounting of components such as reading the PCB load list, checking the components and ensuring correct placement of the components and leads
- Identify the standard operating procedure for bending leads and mounting of components on the board
- Execute steps of soldering of components and handing over the board to wave solder machine operator
- Execute the steps for program loading and check that components are automatically inserted
- Execute daily maintenance tasks
- Identify the documents related to work such as work requirement, manuals, delivery standards, and company policies and so on

Unit 2.1 Manual mounting & placement of components

Unit Objectives

By the end of this unit, participants will be able to:

- List the procedure for manual mounting of components such as reading the PCB load list, checking the components and ensuring correct placement of the components and leads.

2.1.1 Procedure for manual mounting of components such as reading the PCB load list, checking the components and ensuring correct placement of the components and leads

- **Through-hole technology** refers to the mounting scheme used for electronic components that involves the use of leads on the components that are inserted into holes drilled in printed circuit boards (PCB) and soldered to pads on the opposite side either by manual assembly (hand placement) or by the use of automated insertion mount machines.
- Electronics are an integral part of our daily lives. Everything from our smart phones to our cars includes electronic components. At the heart of these electronics is the printed circuit board, also known as a PCB.
- Most people recognize printed circuit boards when they see them. These are the small green chips covered in lines and copper parts you'll find at the heart of gutted electronic devices. Made with fiberglass, copper lines and other metal parts, these boards are held together with epoxy and insulated with a solder mask. This solder mask is where that characteristic green color comes from.
- However, have you ever observed those boards with components solidly stuck on? Never regard them as just decorations of a PCB board. An advanced circuit board won't be able to give its functionality until components are mounted on it. A PCB with components mounted on is called an assembled PCB and the manufacturing process is called PCB assembly or PCBA for short. The copper lines on bare board, called traces, electrically link connectors and components to each other. They run signals between these features, allowing the circuit board to function in a specifically designed way. These functions range from the simple to the complex, and yet the size of PCBs can be smaller than a thumbnail.

PCB Design Basics

The PCBA process always starts out with the most basic unit of the PCB: the base, which consists of several layers, and each one plays a significant role in the functionality of the final PCB. These alternating layers include:

- **Substrate:** This is the base material of a PCB. It gives the PCB its rigidity.
- **Copper:** A thin layer of conductive copper foil is added to each functional side of the PCB — on one side if it's a single-sided PCB, and on both sides if it's a double-sided PCB. This is the layer of copper traces.
- **Solder mask:** On top of the copper layer is the solder mask, which gives each PCB its characteristic green color. It insulates copper traces from unintentionally contacting other conductive materials, which could result in a short. The solder, in other words, keeps everything in its place. Holes in the solder mask are where solder is applied to attach components to the board. Solder mask is a vital step for smooth manufacturing of PCBA since it stops soldering from taking place on unwanted parts with shorts avoided.
- **Silkscreen:** A white silkscreen is the final layer on a PCB board. This layer adds labels to the PCB in the form of characters and symbols. This helps indicate the function of each component on the board.

These materials and components remain largely the same across all PCBs, with the exception of the substrate. The substrate material of a PCB changes according to the specific qualities — such as cost and bendability — each designer is looking for in their finished product.

The three primary PCB types include:

- **Rigid PCB:** The most common type of PCB base is a rigid one that accounts for majority of PCBAs. The solid core of a rigid PCB gives the board rigidity and thickness. These inflexible PCB bases consist of a few different materials. The most common is fiberglass, otherwise designated as “FR4”. Less expensive PCBs are made with materials like epoxies or phenolics, though these are less durable than FR4.
- **Flexible PCB:** Flexible PCBs offer a bit more pliability than their more rigid counterparts. The material of these PCBs tends to be a bendable, high-temperature plastic like Kapton.
- **Metal Core PCB:** These boards are yet another alternative to the typical FR4 board. Made with a metal core, these boards tend to spread heat more efficiently than others. This helps dissipate heat and protect more heat-sensitive board components.

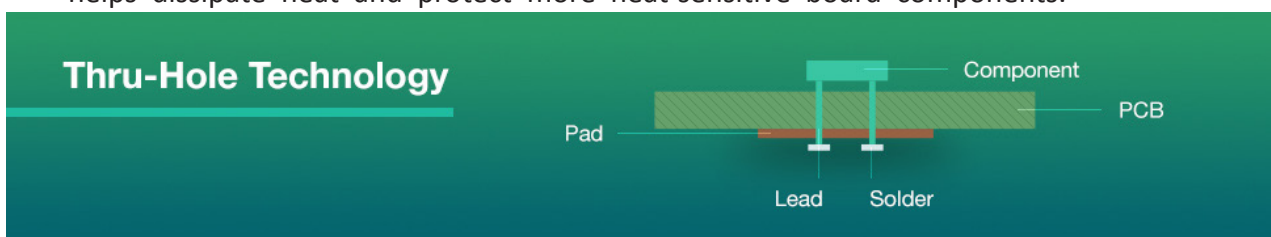


fig. 2.1.1(A) Thru-Hole Technology

There are two types of mounting technologies are prevailing in the modern PCBA industry:

Surface Mount Technology: Sensitive components, some very small, such as resistors or diodes are placed automatically onto the surface of board. This is called SMD assembly, for surface mount device. Surface mount technology can be applied on small size components and integrated circuits (ICs). For example, PCB Cart is capable of mounting package with min. size 01005, which is even smaller than the size of a pencil point.

Thru-Hole Technology: works well on components with leads or wires that have to be mounted on board by plugging them through holes on board. The extra lead part has to be soldered on the other side of the board. This technology is applied on PCB assemblies containing large components such as capacitors, coils to be assembled.

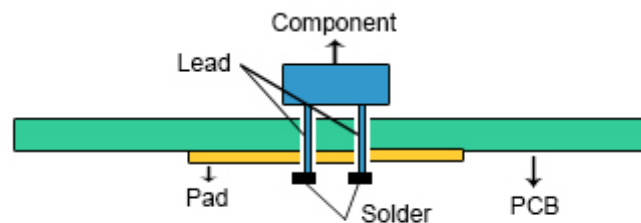


Figure 1 Thru-Hole Technology

Due to distinctions between THT and SMT, they have to go through different assembly processes as well. The following article will discuss other material and design considerations beyond the base of the PCB as they apply to the PCB assembly process in relation to THT, SMT and mixed technologies.

Before the Assembly Process

A few preparatory steps have to happen before real PCBA process even begins. This helps PCB manufacturers assess the functionality of a PCB design, and primarily includes a DFM check.

- Most companies specializing in PCB assembly need the design file of the PCB to start out, along with any other design notes and specific requirements. This is so the PCB assembly company can check the PCB file for any issues that may affect the PCB's functionality or manufacturability. This is a design for manufacturability check, or DFM check, for short.
- The DFM check looks at all the design specifications of a PCB. Specifically, this check looks for any missing, redundant or potentially problematic features. Any of these issues may severely and negatively influence the functionality of the final project. For example, one common PCB design flaw is leaving too little spacing between PCB components. This can result in shorts and other malfunctions.
- By identifying potential problems before manufacturing begins, DFM checks can cut manufacturing costs and eliminate unforeseen expenses. This is because these checks cut down on the number of scrapped boards. As part of our commitment to quality at a low cost, DFM checks come standard with every PCB Cart project order. PCB Cart provides FREE DFM and DFA check with, however, priceless values because Valor DFM/DFA check PCB Cart depends on is an automatic system contributing to high speed and accuracies.

Actual PCBA process steps

Step 1: Solder Paste Stenciling

The first step of PCB assembly is applying a solder paste to the board. This process is like screen-printing a shirt, except instead of a mask, a thin, stainless-steel stencil is placed over the PCB. This allows assemblers to apply solder paste only to certain parts of the would-be PCB. These parts are where components will sit in the finished PCB.

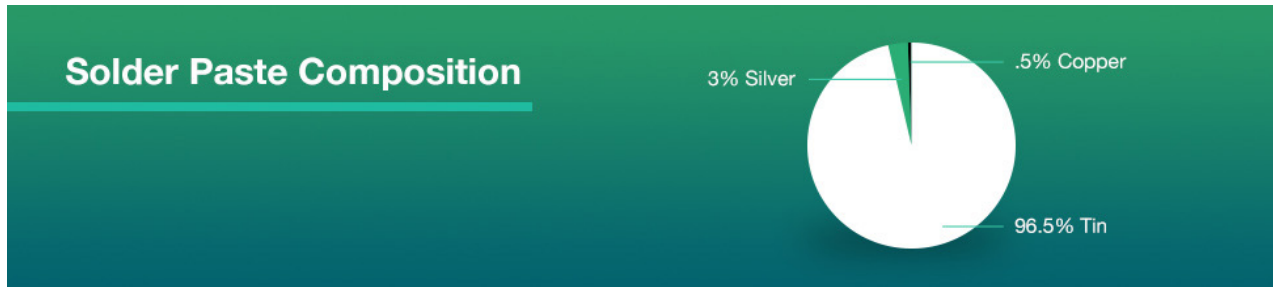


fig. 2.1.1(B) Solder paste composition

The solder paste itself is a greyish substance consisting of tiny balls of metal, also known as solder. The composition of these tiny metal balls is 96.5% tin, 3% silver and 0.5% copper. The solder paste mixes solder with a flux, which is a chemical designed help the solder melt and bond to a surface. Solder paste appears as a grey paste and must be applied to the board at exactly the right places and in precisely the right amounts.

In a professional PCBA line, a mechanical fixture holds the PCB and solder stencil in place. An applicator then places solder paste on the intended areas in precise amounts. The machine then spreads the paste across the stencil, applying it evenly to every open area. After removing the stencil, the solder paste remains in the intended locations.

Step 2: Pick and Place

After applying the solder paste to the PCB board, the PCBA process moves on to the pick and place machine, a robotic device places surface mount components, or SMDs, on a prepared PCB. SMDs account for most non-connector components on PCBs today. These SMDs are then soldered on to the surface of the board in the next step of PCBA process.

Traditionally, this was a manual process done with a pair of tweezers, in which assemblers had to pick and place components by hand. These days, thankfully, this step is an automated process among PCB manufacturers. This shift occurred largely because machines tend to be more accurate and more consistent than humans. While humans can work quickly, fatigue and eyestrain tends to set in after a few hours working with such small components. Machines work around the clock without such fatigue.

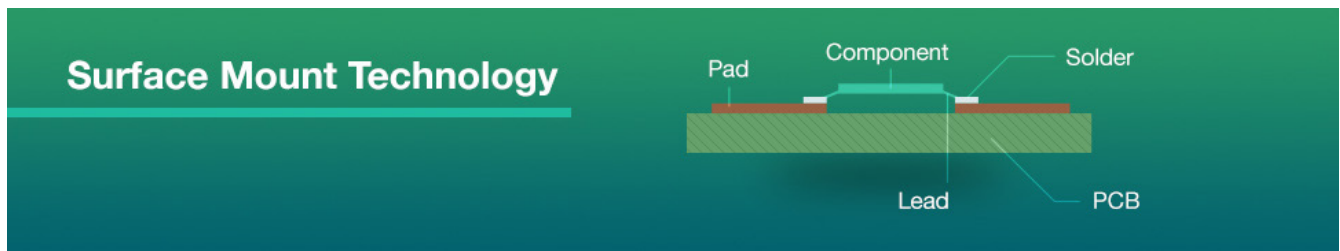


fig. 2.1.1(C) Surface mount technology

The device starts the pick and place process by picking up a PCB board with a vacuum grip and moving it to the pick and place station. The robot then orients the PCB at the station and begins applying the SMTs to the PCB surface. These components are placed on top of the soldering paste in pre-programmed locations.

Step 3: Reflow Soldering

Once the solder paste and surface mount components are all in place, they need to remain there. This means the solder paste needs to solidify, adhering components to the board. PCB assembly accomplishes this through a process called “reflow”.

After the pick and place process concludes, the PCB board is transferred to a conveyor belt. This conveyor belt moves through a large reflow oven, which is somewhat like a commercial pizza oven. This oven consists of a series of heaters which gradually heat the board to temperatures around 250 degrees Celsius, or 480 degrees Fahrenheit. This is hot enough to melt the solder in the solder paste.

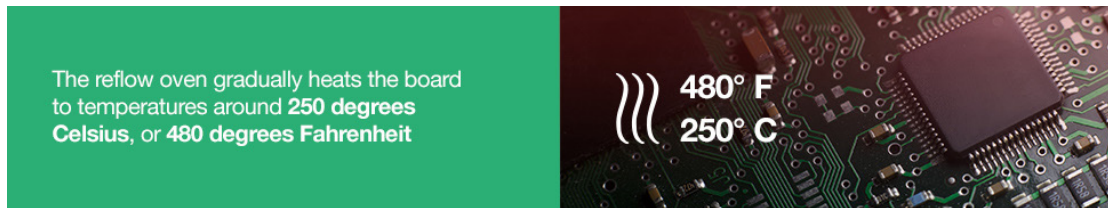


fig. 2.1.1(D) reflow soldering

Once the solder melts, the PCB continues to move through the oven. It passes through a series of cooler heaters, which allows the melted solder to cool and solidify in a controlled manner. This creates a permanent solder joint to connect the SMDs to the PCB.

Many PCBAs require special consideration during reflow, especially for two-sided PCB Assembly. Two-sided PCB assembly need stenciling and reflowing each side separately. First, the side with fewer and smaller parts is stenciled, placed and reflowed, followed by the other side.

Step 4: Inspection and Quality Control

Once the surface mount components are soldered in place after the reflow process, which doesn't stand for completion of PCBA and the assembled board needs to be tested for functionality. Often, movement during the reflow process will result in poor connection quality or a complete lack of a connection. Shorts are also a common side effect of this movement, as misplaced components can sometimes connect portions of the circuit that should not connect.

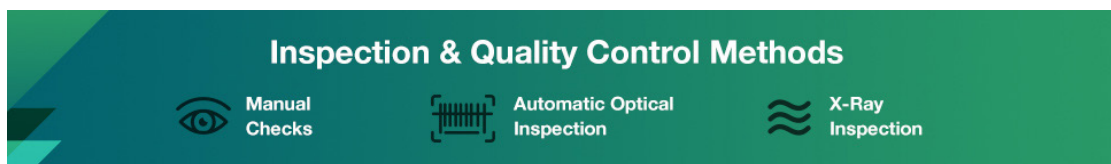


fig. 2.1.1(E) inspection & quality control methods

Checking for these errors and misalignments can involve one of several different inspection methods. The most common inspection methods include:

- **Manual Checks:** Despite upcoming development trend of automated and smart manufacturing, manual checks are still relied on in PCB assembly process. For smaller batches, an in-person visual inspection by a designer is an effective method to ensure the quality of a PCB after the reflow process. However, this method becomes increasingly impractical and inaccurate as the number of inspected boards increases. Looking at such small components for more than an hour can lead to optical fatigue, resulting in less accurate inspections.
- **Automatic Optical Inspection:** Automatic optical inspection is a more appropriate inspection method for larger batches of PCBAs. An automatic optical inspection machine, also known as an AOI machine, uses a series of high-powered cameras to “see” PCBs. These cameras are arranged at different angles to view solder connections. Different quality solder connections reflect light in different ways, allowing the AOI to recognize a lower-quality solder. The AOI does this at a very high speed, allowing it to process a high quantity of PCBs in a relatively short time.
- **X-ray Inspection:** Yet another method of inspection involves x-rays. This is a less common inspection method — it’s used most often for more complex or layered PCBs. The X-ray allows a viewer to see through layers and visualize lower layers to identify any potentially hidden problems.

The fate of a malfunctioning board depends on PCBA company’s standards, they will be sent back to be cleared and reworked, or scrapped.

Whether an inspection finds one of these mistakes or not, the next step of the process is to test the part to make sure it does what it’s supposed to do. This involves testing the PCB connections for quality. Boards requiring programming or calibration require even more steps to test proper functionality.

Such inspections can occur regularly after the reflow process to identify any potential problems. These regular checks can ensure that errors are found and fixed as soon as possible, which helps both the manufacturer and the designer save time, labour and materials.

Step 5: Through-Hole Component Insertion

Depending on the type of board under PCBA, the board may include a variety of components beyond the usual SMDs. These include plated through-hole components, or PTH components.

A plated through-hole is a hole in the PCB that's plated all the way through the board. PCB components use these holes to pass a signal from one side of the board to the other. In this case, soldering paste won't do any good, as the paste will run straight through the hole without a chance to adhere.

Instead of soldering paste, PTH components require a more specialized kind of soldering method in later PCB assembly process:

- **Manual Soldering:** Manual through-hole insertion is a straightforward process. Typically, one person at a single station will be tasked with inserting one component into a designated PTH. Once they're finished, the board is transferred to the next station, where another person is working on inserting a different component. The cycle continues for each PTH that needs to be outfitted. *This can be a lengthy process, depending on how many PTH components need to be inserted during one cycle of PCBA. Most companies specifically try to avoid designing with PTH components for this very purpose, but PTH components are still common among PCB designs.*
- **Wave Soldering:** Wave soldering is the automated version of manual soldering, but involves a very different process. Once the PTH component is put in place, the board is put on yet another conveyor belt. This time, the conveyor belt runs through a specialized oven where a wave of molten solder washes over the bottom of the board. This solders all of the pins on the bottom of the board at once. *This kind of soldering is nearly impossible for double-sided PCBs, as soldering the entire PCB side would render any delicate electronic components useless.*

After this soldering process is finished, the PCB can move on to the final inspection, or it can run through the previous steps if the PCB needs additional parts added or another side assembled.

Step 6: Final Inspection and Functional Test

After the soldering step of the PCBA process is finished, a final inspection will test the PCB for its functionality. This inspection is known as a “functional test”. The test puts the PCB through its paces, simulating the normal circumstances in which the PCB will operate. Power and simulated signals run through the PCB in this test while testers monitor the PCB’s electrical characteristics.



fig. 2.1.1(F) functional test

If any of these characteristics, including voltage, current or signal output, show unacceptable fluctuation or hit peaks outside of a predetermined range, the PCB fails the test. The failed PCB can then be recycled or scrapped, depending on the company’s standards.

Testing is the final and most important step in PCB assembly process, as it determines the success or failure of the process. This testing is also the reason why regular testing and inspection throughout the assembly process is so important.

After PCBA

Soldering paste leaves behind some amount of flux, while human handling can transfer oils and dirt from fingers and clothing to PCB surface. Once all is done, the results can look a little dingy, which is both an aesthetic and a practical issue.

After months of remaining on a PCB, flux residue starts to smell and feel sticky. It also becomes somewhat acidic, which can damage solder joints over time. Additionally, customer satisfaction tends to suffer when shipments of new PCBs are covered in residue and fingerprints. For these reasons, washing the product after finishing all the soldering steps is important.

A stainless-steel, high-pressure washing apparatus using deionized water is the best tool for removing residue from PCBs. Washing PCBs in deionized water poses no threat to the device. This is because it’s the ions in regular water that do damage to a circuit, not the water itself. Deionized water, therefore, is harmless to PCBs as they undergo a wash cycle.

After washing, a quick drying cycle with compressed air leaves the finished PCBs ready for packaging and shipment.

Differences between PCBAs: THT Assembly, SMT Assembly and Mixed Technology

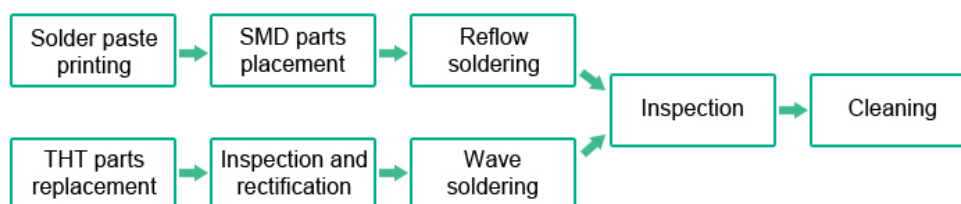


Figure 3 Procedure Comparison between SMT Assembly and THT Assembly

Thru-Hole Technology (THT) Assembly Process

As a traditional PCB assembly method, thru-hole mounting process is accomplished through collaboration of manual procedure and automatic procedure.

- **Step 1: Components Placement** - This step is achieved manually by professional engineering staff. Engineers need to quickly, yet precisely place components on corresponding positions based on client's PCB design files. Component placement must conform to regulations and operation standards of thru-hole mounting process to guarantee high quality end products. For example, they have to clarify polarity and orientation of components, to stop operating component from affecting ambient components, to make completed component placement compatible with corresponding standards and to wear anti-static wristbands when dealing with static-sensitive components like ICs.
- **Step 2: Inspection & Rectification** - Once component placement is completed, the board is then placed in a matching transport frame where board with components plugged in will be automatically inspected so as to determine whether components are accurately placed. If issues concerning component placement are observed, it's easy to get them rectified immediately as well. After all, this takes place prior to soldering in PCBA process.
- **Step 3: Wave Soldering** - Now the THT components should be accurately soldered onto circuit board. In the wave soldering system, the board moves slowly over a wave of liquid solder at high temperature, approximately 500°F. Afterwards, all leads or wires connections can be successfully obtained so that thru-hole components are firmly attached to the board.

Surface Mount Technology (SMT) Assembly Process

Compared with thru-hole mounting process, surface mounting process stands out in terms of manufacturing efficiency because it features a totally automatic mounting PCB assembly process from solder paste printing, pick and place and reflow soldering.

- **Step 1: Solder Paste Printing** - Solder paste is applied on the board through a solder paste printer. A template ensures that solder paste can be accurately left on correct places where components will be mounted, which is also called stencil or solder screen. Because quality of solder paste printing is directly associated with quality of soldering, PCBA manufacturers focusing on high quality products usually carry out inspections after solder paste printing through a solder paste inspector. This inspection guarantees printing has achieved regulations and standards. If defects are found on solder paste printing, printing has to be reworked or solder paste will be washed off prior to second printing.
- **Step 2: Components Mounting** - After coming out of solder paste printer, PCB will be auto-sent to pick-and-place machine where components or ICs will be mounted on corresponding pads in the effect of tension of solder paste. Components are mounted on PCB board through component reels in the machine. Similar to film reels, component reels carrying components rotate to provide parts to the machine, which will quickly stick parts to the board.
- **Step 3: Reflow Soldering** - After every component is placed, the board passes through a 23-foot-long furnace. A temperature of 500°F causes the solder paste to liquefy. Now the SMD components are bound firmly to the board.

Mixed Technology

With the development of modern science and technology, electronic products are becoming increasingly complex, driving complicated, integrated and smaller size PCB boards. It is almost impossible for PCBAs containing only one type of component taking part in.

Most boards carry Thru-hole components and SMD components, which requires collaboration of thru-hole technology and surface mount technology. Nevertheless, soldering is a complicated process that tends to be affected by too many elements. Thus, it becomes extraordinarily significant to better arrange the sequence of thru-hole tech and surface mount technology.

PCBA with application of mixed technologies should be carried out in the following situations:

- **Single Side Mixed Assembly:** Single side mixed assembly conforms to the following manufacturing procedure: Note: Hand soldering can be applied instead of wave soldering when only a small quantity of THT components is required in this type of assembly.

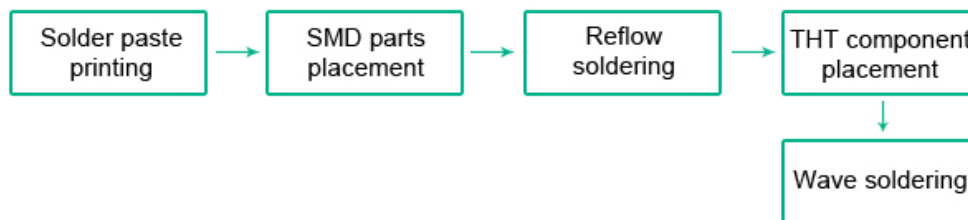


Figure 4 Single side Mixed Assembly Workflow

- **One Side SMT & One Side THT:** Note - This type of PCB assembly procedure is not recommended since adhesives will burden the total cost of PCBA and possibly lead to some soldering issues.

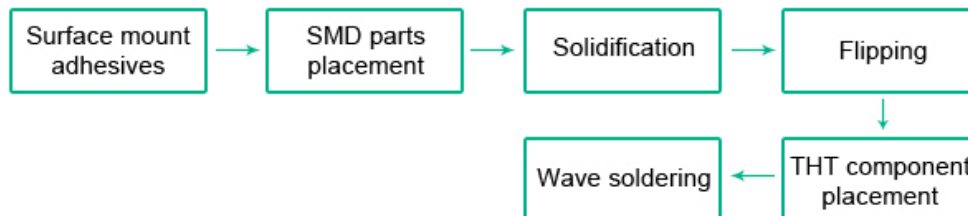


Figure 5 One side SMT, the other side Thru-hole Workflow

- **Double Side Mixed Assembly:** In terms of double side mixed assembly methods, there are two alternatives: PCBA with application of adhesives and PCBA without. The application of adhesives increases the overall cost of PCB assembly. Moreover, during this PCBA process, heating has to be carried out for three times, which tends to lead to low efficiency.

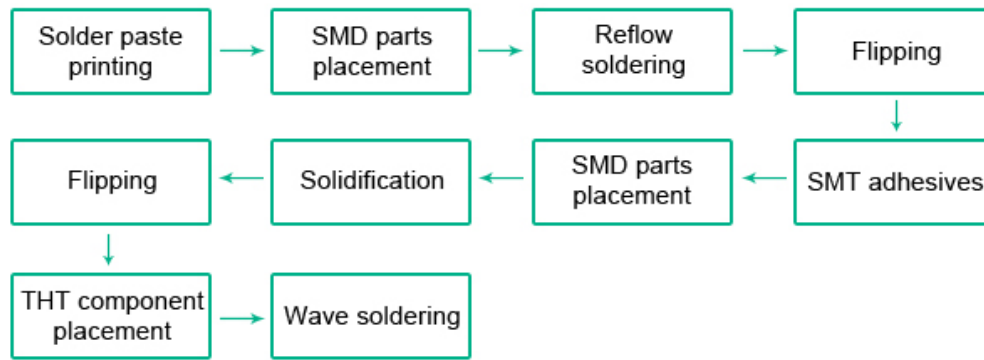


Figure 6 Double side Mixed Assembly Workflow (1)

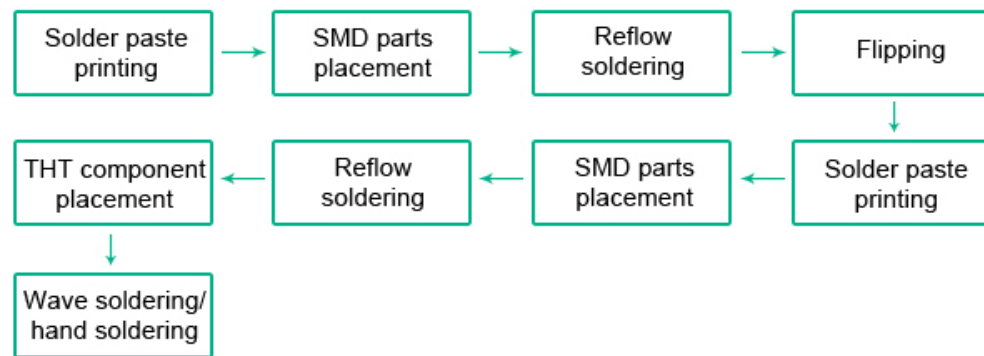


Figure 7 Double side Mixed Assembly Workflow (2)

Based on the comparison between mixed assembly procedures introduced above, it can be concluded that hand soldering works well for PCB assembly that requires with many components on both sides among which SMD components are more than THT components. Therefore, confronted with the situation when a small number of THT components are needed, it is wave soldering that is suggested.

PCB assembly has to go through such a complicated and technical process that numerous elements have to be taken into careful consideration and a little modification may cause huge change on cost and product quality. Descriptions concerning PCB assembly process in this article just center on typical PCBA procedures and technologies. Practical manufacturing process is largely determined and influenced by design files and specific requirement of customers. As a result, how to evaluate a reliable PCB assembler becomes a crucial question customers have to think it over prior to their PCBA order.

Unit 2.2 SOP for bending leads & mounting

Unit Objectives

By the end of this unit, participants will be able to:

1. Identify the standard operating procedure for bending leads and mounting of components on the board.

2.2.1 Identify the standard operating procedure for bending leads and mounting of components on the board

Components mounted to soldering terminals must be provided with a small expansion bend on the leads (Figure 1). Otherwise, we shall run the risk that temperature-dependent contractive forces will be transferred to internal contact areas causing them to fracture and create an open circuit.

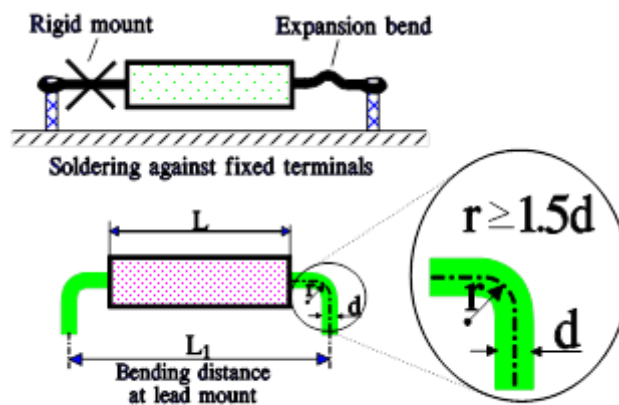


Figure 1: leaded components basic mounting rules, source: CLR HBK

When the connecting leads are bent it has to be done according to specific rules. If we bend too close to the component body, we run a great risk of transferring forces to internal connections that could be damaged. The forces may also cause cracks in hermetic seals. With Figure 8. As a starting point we can write the following equation:

$$L + 3d \leq n \times M = L1 \dots\dots\dots \text{Eq. [1]}$$

where n is the lowest possible integer fulfilling Equation 1. M stands for used modulus of the board layout, 2.5 or 2.54 mm. For small component bodies sometimes half the modulus needs to be used in order not to make the bending distances unnecessarily large. With large bodies standardizing may justify that n is limited only to odd values. Capacitors and magnetic devices (no heat produced) heavier than 5 – 10 gram should be fixed mechanically attached to the substrate.

If power leaded components are soldered to turrets as shown in the top example of Figure 10. we have to ensure that the heat transfer through the leads doesn't melt the solder. In critical cases it may be necessary to choose longer or thinner leads, less heat conductive lead material or, alternatively, we must decrease the power developed in the component or bond it to the PCB with a thermal adhesive.

We must also see to it that the height over the substrate is adequate with respect to allowing sufficient thermal radiation. Heat from the soldering process may, in unfortunate cases, be conducted up through the leads melting the internal solder connections in radial lead components that are mounted close to the circuit board. To avoid this, we should ensure that those connections are made with a high-temperature solder.

Cutting a component lead with side cutting pliers will expose the component to a considerable mechanical shock. This applies also to automatic lead cutters. The shock is of short duration and the magnitude may vary strongly from one type and manufacture to another. If such components are used whose construction may be sensitive to mechanical shocks, the mechanical forces should be measured and the exposure to the cutting forces evaluated. A cutting plier with a flat edge toward the component reduces this shock.

Mounting considerations for single-ended components

The internal structure of single-ended components might be damaged if excessive force is applied to the lead wires. Stresses like push, pull, bend etc. might cause electrical parameters deterioration or open/short circuit, due to rupture of terminals or internal elements.

Pay attention to the following cautions:

- Do not move the component after soldering to the PC board.
- Do not pick up the PC board by holding the soldered component.
- Do not insert component on the PC board with a hole space different to specified lead space.
- Check the recommended component position into consideration when designing the PC board layout.

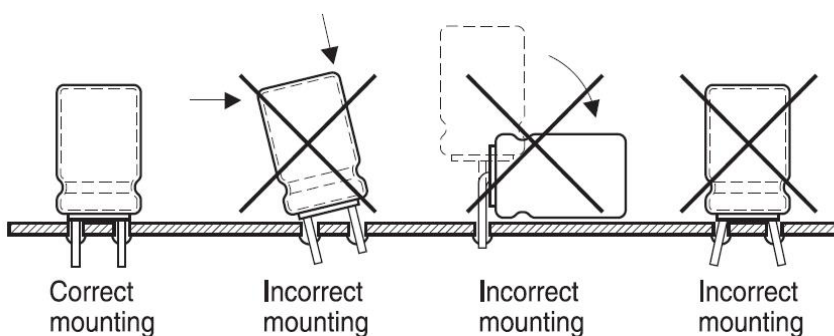


Figure 2: mounting considerations for single-ended capacitors, source: TDK

SMD component pads

It should be designed to achieve good solder filets and minimize component movement during reflow soldering. Pad designs – see manufacturer’s datasheets for pad design recommendations. The basis of these designs may include:

- Pad width equal to component width. It is permissible to decrease this to as low as 85% of component width but it is not advisable to go below this.
- Pad overlap 0.5mm beneath component.
- Pad extension 0.5mm beyond components for reflow and 1.0mm for wave soldering.

Some common pad design related mounting problems and recommendations are shown in Fig.3. Below.

Typical mounting problems


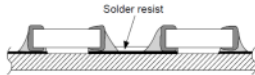
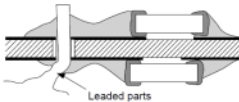
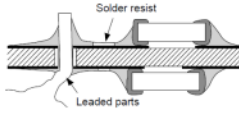
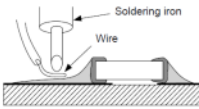
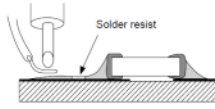
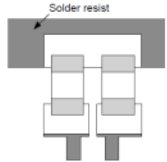
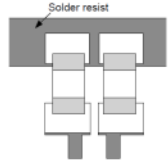
Item	Poor example	Recommended example/Separated by solder resist
Multiple parts mount		
Mount with leaded parts		
Wire soldering after mounting		
Over View		

Figure 3: Typical SMD mounting problems and recommended solution. Source: Kyocera

The correct layout of a **solder resist**, as used in Figure 12. examples, can mitigate certain mounting issues. See Fig.4. a solder resist layout design example on SMD component.

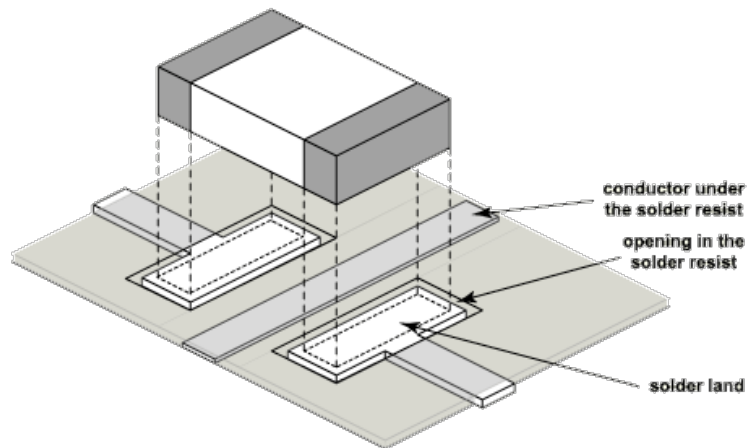
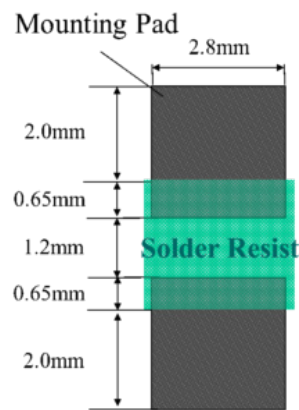
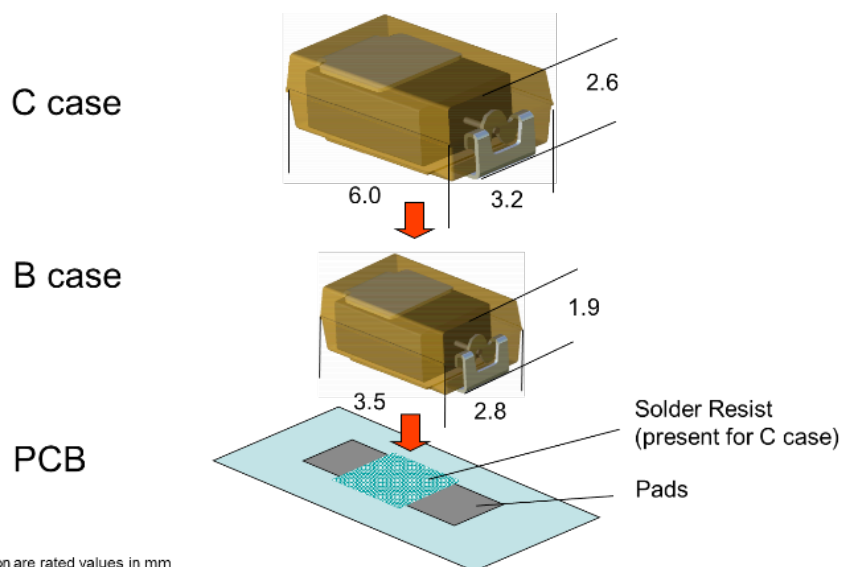


Figure 4: solder resist on a printed wiring board, source: Epectec*



Solder resist can be used also in some cases to modify pad design in a relatively inexpensive way to adjust to a new component or fix a pad layout issue. A flexible pad design concept using solder resist masking that allows flexible replacement of C and B case tantalum capacitors was suggested by AVX – see Fig.5. Smaller B case size can offer cost saving over larger C case size when it is available/qualified without the need of expensive circuit board pad re-design.



dimension are rated values in mm

Figure 5: tantalum capacitors C to B case universal pad design source: AVX

It is important to remember that SMD components, more than the others, are influenced by temperature changes, especially for the larger component. Thus, **dimensions and mounting directions are most important**. Further, short and wide bodies are preferable to long and thin ones, partly for strength reasons, partly because of the inductance and with that the frequency dependence will decrease. Still, another reason is that constraint density in solder joint from the coefficient of expansion between substrate and chip decreases in significance with shorter distances between terminations. This approach results in a strongly improved mechanical strength, better electrical parameters, and thermal dissipation. This would be a typical recommendation for assembly of mechanically sensitive MLCC capacitors – see Fig.6. The same principle works on MLCC “reverse geometry” types, where the terminations are made alongside the longer dimension of the chip.

Recommended chip position on PCB to minimize stress from PCB warpage



Figure 6: recommended MLCC chip PCB position, source: Kyocera

Since the stress to the curvature or bending at the time of breaking printed substrate, may cause a fault when arranging surface mount components near printed substrate breaking point, consideration is required for the method of arrangement of surface mount components.

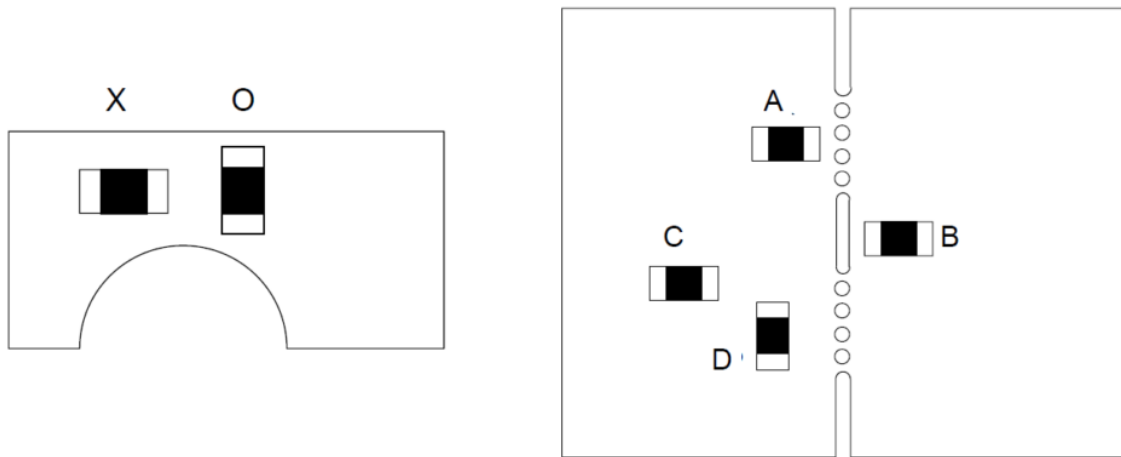


Figure 7: SMD component arrangement close to curvature, bending or PCB crop lines. Source: Panasonic

Figure 7. Illustrates mechanical stress considerations related to the SMD component PCB layout orientation. Risk of mechanical issues on the Figure right side can be assumed:

$$A > C > B >>>>>>>>>> D$$

Therefore, arrange to the broken line of the printed substrate as in parallel as possible, keep away from the break line as much as possible or use milling machine/tool to perform the cut.

Passive components chips may produce also some heat and, to some extent, also SM magnetics. In comparison with lead mount components the heat conduction through the solder joints of the SMDs is good. Hence the relative temperature of the body centre with respect to non-SMDs will decrease and will rise in the solder joints. A wide lead pattern will facilitate the heat transfer still more. It will allow a larger electric load before we reach the specified "hot spot" temperature. Nevertheless, the thermal dissipation and radiation have to be considered during the PCB and pad layout design.

Because of their size, SMD styles always must be furnished with flexible leads in order to prevent damage during temperature cycles. Heavier components, in order to prevent them from coming loose when subjected to shock or vibration, should be mechanically attached to their substrate by means of an adhesive or staking compound.

Component Spacing

For wave soldering, components must be spaced sufficiently far apart to avoid bridging or shadowing (inability of solder to penetrate properly into small spaces). This is less important for reflow soldering but sufficient space must be allowed to enable rework should it be required. At least 0.5 mm air space or additional insulation should separate components from adjacent metal parts, for example, conductive patterns on printed circuit boards.

Component Handling

Commercial non-hermetic components should be handled with care to avoid damage or contamination from perspiration and skin oils. The use of tweezers or vacuum pick-ups is strongly recommended for individual components. Bulk handling should ensure that abrasion and mechanical shock are minimized. Taped and reeled components provide the ideal medium for direct presentation to the placement machine. Any mechanical shock should be minimized during handling of components, especially chip multilayer ceramic capacitors.

Multiple leads components (such as some SMD film capacitors, arrays etc.) terminations flatness shall be maintained and it may not be modified during the different component mounting steps (cleaning, assembling, ...). Solder wetting may not be sufficient on all terminations equally if for example one lead is not bent far enough and it doesn't touch the PADs completely on its surface.

Leaded components should not be handled by terminals or by connections. It is advisable to short-circuit the connections of high voltage capacitors (over 120V in a normal environment) after their use under D.C. voltage, as certain dielectrics keep a residual charge which might be dangerous during handling operations.

The fluid impregnated capacitors, unless otherwise specified, shall be mounted with the terminals faced upwards. A free gap shall be allowed between battery-mounted capacitors. Cables, bars or connecting braids shall be properly dimensioned to prevent any abnormal temperature rise of the terminals. It is also preferable to connect battery-mounted capacitors by means of flexible cables or by braids.

Thin-film and some small passive components can exhibit some sensitivity level to Electrostatic Discharge (ESD), ESD charge/discharge voltage can exceed a tenth of kilo-Volts and the ESD typical charge current can be around 1 to 10A in many cases. Please refer to the manufacturing datasheets about ESD sensitivity of the specific component. ESD sensitive components shall be handled with an ESD conform tweezers and if handled manually, please wear anti-static wrist strap and finger gloves to avoid ESD stress and dust. ESD may not be considered as a critical factor for high capacitance, high charge storage capacitors such as electrolytic capacitors on the other hand. The amount of ESD charge can be easily absorbed by high capacitance devices without a substantial increase of the applied voltage. For ESD classification and further info please refer to IPC/JEDEC-EIA-625 standard.

Moisture sensitive device is necessary to be handled and processed following its moisture sensitivity level (MSL) as per industrial standard J-STD-033C. The MSL rated component has to be dry packed with humidity indicator and caution statement – see Fig. 8.

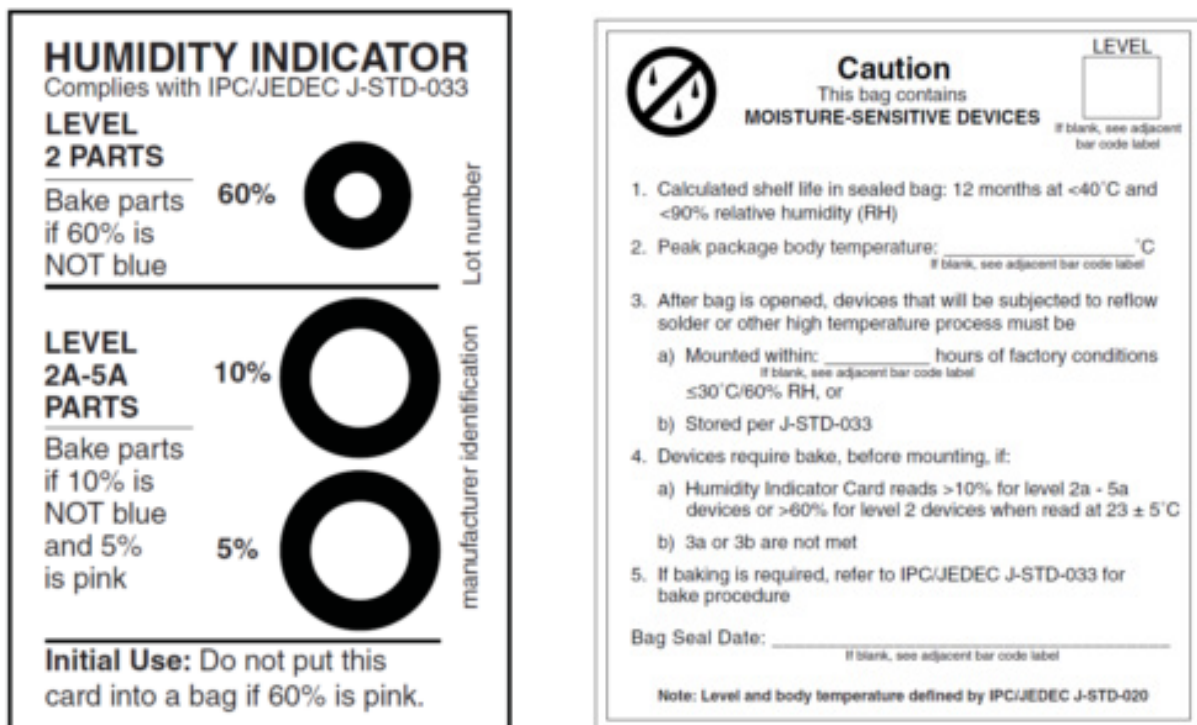


Figure 8: Example of humidity indicator and caution statement as per the J-STD-033C

The components shall be processed within an indicated floor life time. Drying and baking before mounting in accordance to the caution instructions are required in case of longer exposure after the bag is opened. MSL classification and floor life time – see fig.9.

Pick & Place

Fast pick and place on large boards may also induce some cracks in chip components such as MLCC capacitors during the component placement. Pressure applied by the Pick and Place nozzle during placement should be carefully monitored and limited. Use of supporting pins to the other PCBs side may limit the board bending and thus reduce mechanical stress to MLCCs. See the following Fig 10.

Moisture Sensitivity Level	Floor Life (out of bag) at factory ambient ≤ 30 °C/60% RH or as stated
1	Unlimited at ≤ 30 °C/85% RH
2	1 year
2a	4 weeks
3	168 hours
4	72 hours
5	48 hours
5a	24 hours
6	Mandatory bake before use. After bake, must be reflowed within the time limit specified on the label.

Figure 9: Moisture classification and floor life – refer to J-STD-033C

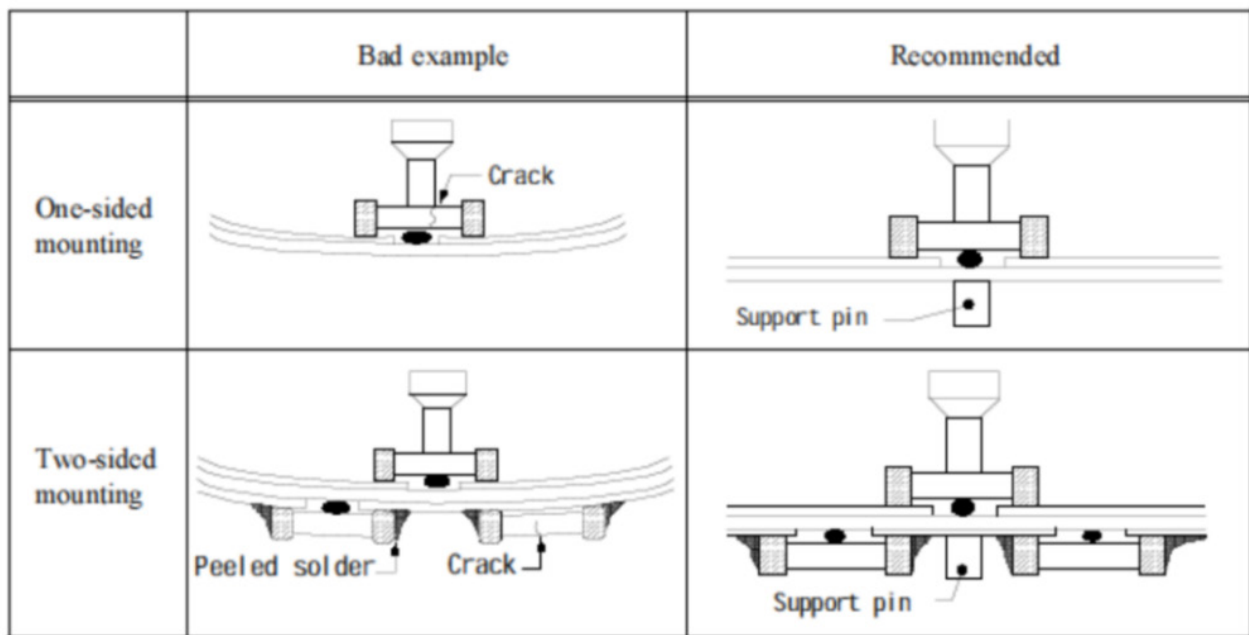
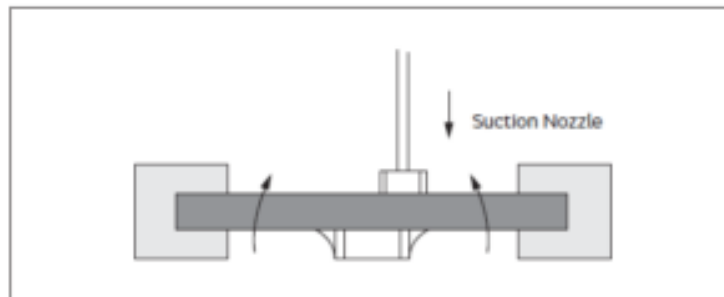


Figure 10: large board flex suppression by support pins, source: Kyocera

Pick and Place of nearby Components (source: Murata)

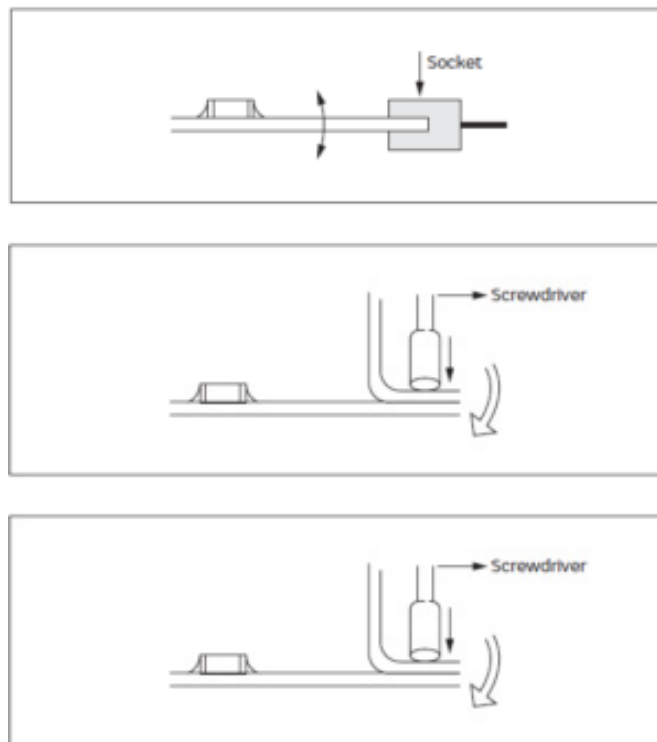


Pick and place of nearby and opposite side components can also cause some flex and PCB vibration. Board deflection stress may damage the back side (bottom side) components if the bottom dead point of the suction nozzle is set too low. After the board is straightened, it is important to set the bottom dead point of the nozzle on the upper surface of the board. Periodical check and adjustment of the bottom dead point is advised as a preventive measure.

When inserting larger leaded components (transformers, etc.) into boards, the board bending may cause cracks in chip components or cracks in solder joints. The insertion stress can be reduced by appropriate hole size enlargement. It is recommended to fix the board with support pins or a dedicated jig before insertion. Periodically check that there is no difference in the height of each support pin during mass production.

Insertion and removal of sockets and connectors, etc., might be an additional cause of board bending. The board shall not warp during insertion and removal of sockets and connectors, etc.

The board may be bent, when tightening screws during attachment of the board to a shield or chassis etc. Mechanical assembly process shall be prepared to minimize board bending, flexing or vibration. Use of torque screwdriver is recommended to prevent over-tightening of the screws. Please note that the board straightness may be impacted by thermal reflow soldering stress. The stress may be applied to the chips by forcibly flattening the board when tightening the screws.



Unit 2.3 Soldering

Unit Objectives

By the end of this unit, participants will be able to:

- Execute steps of soldering of components and handing over the board to wave solder machine operator
- Execute the steps for program loading and check that components are automatically inserted

2.3.1 Execute steps of soldering of components and handing over the board to wave solder machine operator

- Soldering is a process in which two or more metal items are joined together by melting and then flowing a filler metal into the joint—the filler metal having a relatively low melting point.
- Soldering is used to form a permanent connection between electronic components.
- The metal to be soldered is heated with a soldering iron and then solder is melted into the connection.
- Only the solder melts, not the parts that are being soldered.
- Solder is a metallic “glue” that holds the parts together and forms a connection that allows electrical current to flow.
- You can use a solderless breadboard to make test circuits, but if you want your circuit to last for more than a few days, you will want to solder the components together.

Materials and Equipment

A soldering iron

- A soldering iron is used to heat the connections to be soldered.
- For electronic circuits, you should use a 25- to 40-watt (W) soldering iron.
- Higher wattage soldering irons are not necessarily hotter; they are just able to heat larger components. A 40-W soldering iron makes joints faster than a 25-W soldering iron does.
- A soldering iron can be purchased at hardware stores and at most large department stores.

Rosin core solder

- Solder has a lower melting point than the metals that are being connected do. The solder melts when it is heated by the soldering iron, but the metals being joined will not melt.
- The rosin core acts as a flux. It prevents oxidation of the metals that are being connected, and enhances the ability of the solder to “wet” the surfaces that are being joined.
- Solder that is used to join copper pipes has an acid core, which is appropriate for pipes, but will corrode electronic connections. Use solder that has a rosin core.
- For most electronics work, a solder with a diameter of 0.75 millimeters (mm) to 1.0 mm is best. Thicker solder might make soldering small joints difficult and also increases the chances of creating solder bridges between copper pads that are not meant to be connected.
- An alloy of 60/40 (60% tin, 40% lead) is used for most electronics work, but lead-free solders are available as well.

Stand on which to hold the hot soldering iron

- There are a variety of stands available. It is important to always keep the hot iron in its stand when not in use.

Sponge

- The damp sponge is used to clean the tip of the iron.

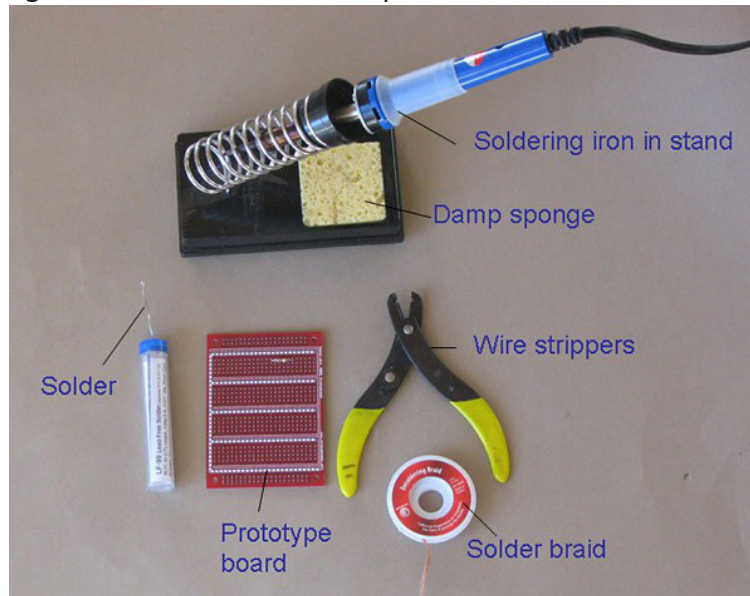


Figure 1. Soldering equipment and materials.

The *solder* in this picture is coiled inside a plastic tube; it is pulled through the top as needed. The spring on the stand holds the hot soldering iron. The *damp sponge* is used to clean the tip of the iron. *Solder braid* is used to remove solder; solder is “soaked up” into the braid when it is heated by the soldering iron. The *wire strippers* can be adjusted to strip the plastic covering off of various thicknesses of wire. The *prototype board* is used to connect electronic components in a circuit.

Solder braid

- This is used to remove solder.
- To use the braid, place it over the solder to be removed and heat it from above with the iron. The solder will flow into the braid.
- Solder braid is used to extract an electronic component that is soldered onto a board.
- It is also used to reduce the amount of solder on a connection.

Prototype board

- A prototype board is used to assemble the circuit.
- Prototype boards have copper tracks or pads for connecting components.

Steel wool or fine sandpaper

- This is used to clean connections prior to soldering.
- Solder will not flow over a dirty connection.

Crocodile clips

These can be used as heat sinks, if needed.

Safety & Tips

Safety Precautions

1. **Caution:** A soldering iron can heat to around 400°C, which can burn you or start a fire, so use it carefully.
2. Unplug the iron when it is not in use.
3. Keep the power cord away from spots where it can be tripped over.
4. Take great care to avoid touching the tip of the soldering iron on a power line. If a power cord is touched by a hot iron, there is a serious risk of burns and electric shock.
5. Always return the soldering iron to its stand when it is not in use.
6. Never put the soldering iron down on your work bench, even for a moment!
7. Work in a well-ventilated area.
8. The smoke that will form as you melt solder is mostly from the flux and can be quite irritating. Avoid breathing it by keeping your head to the side of, not above, your work.
9. Solder contains lead, which is a poisonous metal. Wash your hands after using solder.

Tips

Reliable operation of a circuit with soldered connections depends on good soldering practices. Here are some tips for successful soldering.

1. Plan before you start to solder. Identify all the parts that you will be using.
2. It is helpful to attach each part to a piece of paper and write what it is and its value (for example, resistor #1: 100 ohms).
3. Some components, such as LED's, must be placed the correct way around in order to function.
4. The following is a suggested order for the installation of various components:
 - Integrated circuit (IC) holders (note the orientation). The IC will be added later.
 - Resistors
 - Capacitors, less than 1 micro farad
 - Large capacitors, 1 micro farad or greater, note the orientation.
 - Diodes, note the orientation.
 - LED's, note the orientation.
 - Transistors, note the orientation.
 - Solid wire connections between components on the board
 - Solid wire is fairly rigid, so it will stay in place once attached.
 - Stranded wire to parts that are connected by wire to the circuit
 - Stranded wire is more flexible than solid wire.
 - Integrated circuits
 - Connect them the correct way around.
 - Many IC's are static sensitive.
 - Leave IC's in their antistatic packaging until you need them, then ground your hands by touching a metal water pipe or window frame before touching the IC's.
 - Carefully insert IC's in their holders. Make sure all the pins are lined up with the socket, then push down firmly with your thumb.

Preparing

Preparing the Soldering Iron: Tinning the Tip

1. Place the soldering iron in its stand and plug it in.
2. Wait for the soldering iron to heat up.
3. Moisten the sponge.
4. Wipe the tip of the iron on the damp sponge. This will clean the tip.
5. Melt a little solder on the tip of the iron.
 - This is called *tinning* and it will help the heat flow from the iron's tip to the joint.
 - The solder should flow onto the tip, producing a bright shiny surface.
 - If the solder will not flow onto the tip, clean it by wiping it on the wet sponge.
 - When tinned, wipe excess solder off on the wet sponge.
 - You do not need to tin the tip before every joint, but you should re-tin it if it has gone dull when the soldering iron has not been used for a few minutes.
 - Check the manufacturer's instructions related to tinning the tip.
6. The tip of the soldering iron should be a shiny silver color. If it is black and pitted, replace it with a new one.

Soldering

1. Solder needs a clean surface on which to adhere.
 - Buff the copper foil of a PC board with steel wool before soldering.
 - Remove any oil, paint, wax, etc. with a solvent, steel wool, or fine sandpaper.
2. To solder, heat the connection with the tip of the soldering iron for a few seconds, then apply the solder.
 - Heat the connection, not the solder.
 - Hold the soldering iron like a pen, near the base of the handle.
 - Both parts that are being soldered have to be hot to form a good connection.

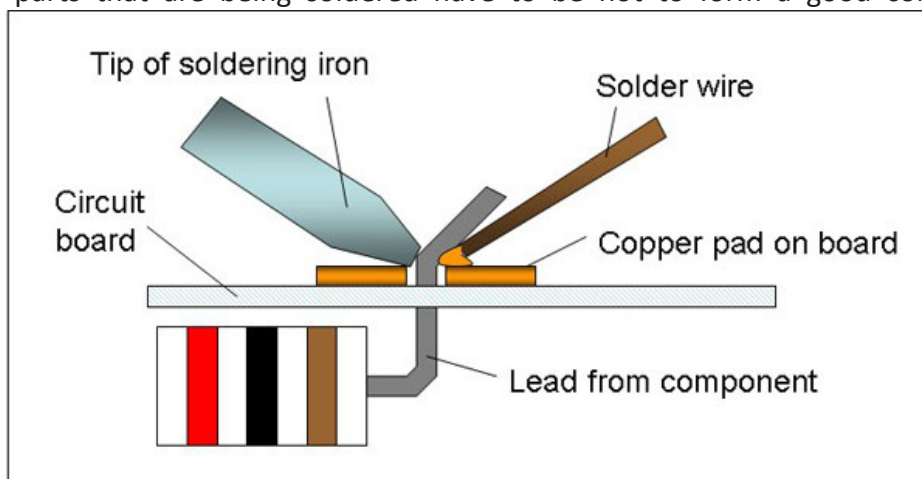


Figure 2. The tip of the soldering iron heats both the copper pad and the lead from the electronic component. Solder melts when placed in contact with the hot metals to be joined.

3. Keep the soldering tip on the connection as the solder is applied.
 - Solder will flow into and around well-heated connections.
 - Use just enough solder to form a strong connection.

4. Remove the tip from the connection as soon as the solder has flowed where you want it to be. Remove the solder, then the iron.
5. Don't move the connection while the solder is cooling.
6. Don't overheat the connection, as this might damage the electrical component you are soldering.
 - Transistors and some other components can be damaged by heat when soldering. A crocodile clip can be used as a heat sink to protect these components.

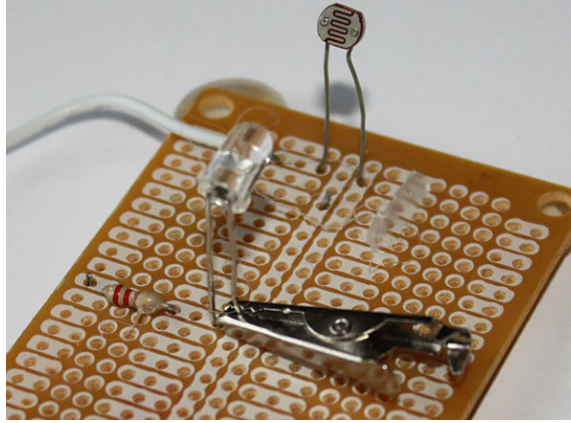


Figure 3. By absorbing heat, the crocodile clip will reduce the heat that flows to the component, helping to prevent damage.

7. Soldering a connection should take just a few seconds.
 - If it is taking longer, see the troubleshooting section below.
8. Inspect the joint closely. It should look shiny (note: lead-free solder may appear dull, this is OK).
 - If you are soldering a wire (called the lead) onto a PC board (on the track), it should have a volcano shape. See Figure 3.
 - If the connection looks bad, reheat it and try again.

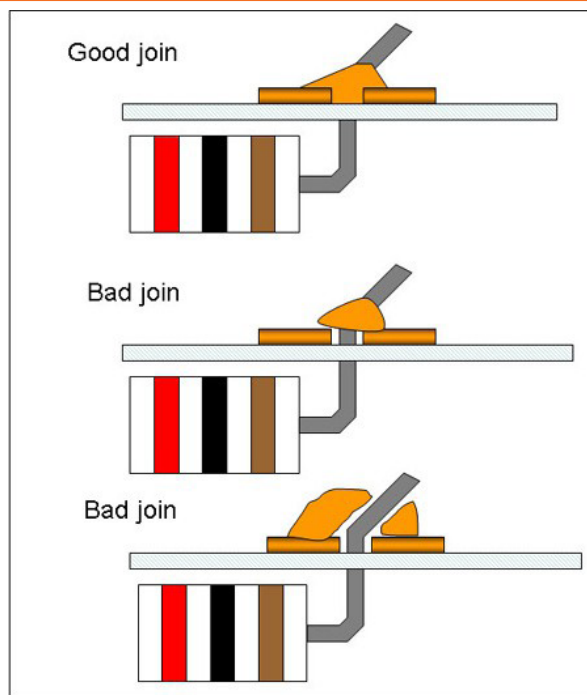


Figure 4. The solder in a good join will be shaped like a cone, with solid contact between the solder and all surfaces to be joined. Bad joins (also called dry joints) should be melted and remade.

9. Wipe the tip of the iron on a damp sponge to clean it. The tip should now be shiny.
10. Unplug the soldering iron when it is not in use.

Troubleshooting

Common Problems and Troubleshooting

1. Solder will not flow.
 - The parts to be joined may be dirty. Remove the solder and clean the parts.
2. The connection looks grainy or crystalline.
 - Parts were moved before the solder was allowed to cool. Reheat to form a good joint. You may need a larger soldering iron to heat connections adequately.
3. The tip is oxidized.
 - Soldering is much easier with a shiny, clean tip.
 - Clean the tip with a damp synthetic sponge while the iron is hot.
 - To avoid oxidizing the tip, do not leave the iron plugged in when not in use.
 - Do not use the iron at a higher temperature than is necessary to melt solder.
 - Clean the tip of the iron on a damp synthetic sponge as soon as it starts to change from a silver color.
4. There is too much or too little solder.
 - Using too much solder can cause a solder bridge, which means that two adjacent joints are accidentally connected.
 - Using too little solder might result in poor electrical continuity between the board and component. The connection should be smooth, shiny, and rigid.

2.3.2 Wave soldering

Wave soldering is a bulk soldering process used for the manufacturing of printed circuit boards. The circuit board is passed over a pan of molten solder in which a pump produces an upwelling of solder that looks like a standing wave. As the circuit board makes contact with this wave, the components become soldered to the board. Wave soldering is used for both through-hole printed circuit assemblies, and surface mount.

As through-hole components have been largely replaced by surface mount components, wave soldering has been supplanted by reflow soldering methods in many large-scale electronics applications. However, there is still significant wave soldering where surface-mount technology (SMT) is not suitable (e.g., large power devices and high pin count connectors), or where simple through-hole technology prevails (certain major appliances).

Wave solder process

There are many types of wave solder machines; however, the basic components and principles of these machines are the same. The basic equipment used during the process is a conveyor that moves the PCB through the different zones, a pan of solder used in the soldering process, a pump that produces the actual wave, the sprayer for the flux and the preheating pad. The solder is usually a mixture of metals. A typical leaded solder is composed of 50% tin, 49.5% lead, and 0.5% antimony. The Restriction of Hazardous Substances Directive (RoHS) has led to an ongoing transition away from 'traditional' leaded solder in modern manufacturing in favor of lead-free alternatives. Both tin-silver-copper and tin-copper-nickel alloys are commonly used, with one common alloy (SN100C) being 99.25% tin, 0.7% copper, 0.05% nickel and <0.01% germanium.

2.3.3 Designing a printed circuit board

1. Understand the electrical parameters

Before starting a PCB design, you should know and understand the electrical parameters of the system, including:

- Current maximums
- Voltages
- Signal types
- Capacitance limitations
- Impedance characteristics
- Shielding considerations
- Type and location of circuit components and connectors
- Detailed net wire listing and schematic

2. Creating the schematic

One of the first steps is always creating a schematic, which refers to the design at the electrical level of the board's purpose and function. At this point, it's not yet a mechanical representation.

3. Use a schematic capture tool to create your PCB layout

The right PCB provider will work with principal engineers to develop a schematic with a software platform such as Mentor PADS®, Allegro, or Altium, which shows you exactly how your board will operate and where the components will be placed. After you create your schematic, the mechanical engineer will load the design and determine how it will fit in the intended device.

4. Design your PCB stackup

This is important to consider early on in the PCB design stage due to impedance, which refers to how much and how quickly electricity can travel down a trace. The stackup plays a role in how the mechanical engineer can design and fit the PCB into the device.

5. Define design rules and requirement

This step is largely dictated by standards and acceptability criteria from the IPC, which is the industry association for PCB and electronics manufacturing. These standards tell you everything you need to know regarding PCB manufacturing. An important tip: Find a PCB layout provider who is extremely familiar with IPC standards; this can help you avoid major revisions and project delays.

6. Place your components

In many cases, the customer and PCB provider will discuss design and layout guidelines when it comes to the placement of components. For example, there may be standards indicating that certain components cannot be placed near others because they create electrical noise in the circuit. The PCB provider will have data sheets on every component (in most cases these are connectors), which will then be placed in the mechanical layout and sent to the customer for approval.

7. Insert drill holes

This step is driven by the components and a connection. About half of the flex circuits on the market are double-sided, which means they have connection to the drill hole on the bottom layer.

8. Route the traces

After you've placed the components and drill holes, you're ready to route the traces, which means connecting segments of the path.

9. Add labels and identifiers

Now is the time to add any labels, identifiers, markings, or reference designators to the layout. Reference designators are helpful in showing where specific components will go on the board.

10. Generate design/layout files

This is the final step in the layout process. These files contain all the information pertaining to your printed circuit board, and once they have been generated, your PCB is now ready for fabrication and manufacturing and assembly.

PCB Composition & Materials

A copper-clad substrate or polyimide-based film is often used for flex circuits, and FR4 (or an FR4 stiffener) is used for rigid-flex. FR4 allows you to build up the layers as the technology content is created.

A solder mask is also used, which is a technique where everything on the circuit board is coated with an epoxy-based LPI or cover coat for flex, except the contacts to be soldered, the gold-plated terminals of any card-edge connectors, and fiducial marks.

Unit 2.4 Daily maintenance & Documentation

Unit Objectives

By the end of this unit, participants will be able to:

- Execute daily maintenance tasks
- Identify the documents related to work such as work requirement, manuals, delivery standards, company policies and so on

2.4.1 Daily maintenance tasks

- The technical meaning of **maintenance** involves functional checks, servicing, repairing or replacing of necessary devices, equipment, and machinery, building infrastructure, and supporting utilities in industrial, business, and residential installations.
- Electrical maintenance is the process of electrical systems inspection, testing, monitoring and replacing all electrical parts as required, using hand tools, thermal imaging, computerized programs and special measurement devices, to keep systems and machines working efficiently and safely.
- **Corrective maintenance** it is task performed to identify, isolate, and repair a fault which is actually happened.
- **Preventive maintenance, also referred to as PM, is a planned maintenance that means performing regular time based maintenance on electrical equipment, So that it wouldn't break unexpectedly.**
- **Predictive maintenance is determined by the condition of equipment rather than expected life statistics.** Predictive maintenance evaluates the condition of equipment by performing periodic (offline) or continuous (online) equipment condition monitoring.
- To evaluate equipment condition, predictive maintenance utilizes non-destructive testing technologies such as infrared, thermal imaging, partial discharge, corona detection, rotating machines (like electrical motors) vibration analysis, sound level measurements and electrical transformer oil analysis.

2.4.2 Company's documentation policy

- The ultimate dream of every business owner is to have efficient employees, effective communication, and growth! Yet, maintaining all three together is not that easy!
- The more your company grows, the harder it gets to effectively communicate, and eventually more difficult it becomes to ensure that your employees carry out their tasks efficiently aligned with the objectives of your company!
- To maintain a successful cycle, your company needs rules and guidelines to manage employees for a smooth workflow. They also, in turn, need constant assurance that the company has their best interests at heart!
- However, accomplishing all this can be overwhelming without some kind of help. This is where the need to create a policies & procedures manual comes in.
- Every company needs a policies & procedures manual to guide its operations, strategy, and workflow. Where policies set the expectation for employee behaviors, the procedures outline the steps for it. This ensures consistency in practice and helps in maintaining quality output.
- A policy and procedure manual is the perfect way to keep your virtual employees on the same page as these manuals work like references in case someone is confused about taking a step or decision-making and enables everyone to behave in a legal, conscious, and ethical manner.

Here are some items that should be included in the policies and procedures manual:

- Employment procedures
- Work from home policies
- Organization culture
- Employee benefits
- Communication policies
- Payment procedures
- Workplace guidelines
- Employee code of conduct
- Technology usage procedures

2.4.3 Discuss organisational policies on incentives, delivery standards, personnel management and public relations (PR).

The organizational policies on incentives, personnel management, and reporting structure depend on the organization the individual joins. These vary across organizations.

For example, a public sector company may offer different kinds of incentives for work performance as compared to a private company. The same is the case with the reporting structure.

Personnel management policies also tend to differ from organization to organization. The individual should conduct proper research before interviewing for a job at a particular company to ensure that they are satisfied with the company policies on remuneration, human resource management, career progression, etc.

EXERCISE **Short Questions**

1. Explain solder mask.
2. What is rigid PCB?
3. What is flexible PCB?
4. Define automatic optical inspection.
5. Explain reflow soldering.

Long Questions

1. List the procedure for manual mounting of components such as reading the PCB load list, checking the components and ensuring correct placement of the components and leads.
2. Identify the standard operating procedure for bending leads and mounting of components on the board.
3. Execute steps of soldering of components and handing over the board to wave solder machine operator.
4. Execute the steps for program loading and check that components are automatically inserted.
5. Execute daily maintenance tasks.
6. Identify the documents related to work such as work requirement, manuals, delivery standards, and company policies and so on.

Notes



Notes



A large rectangular area containing 20 horizontal lines for taking notes.

Notes



Lined area for taking notes, enclosed in a rectangular border.



3. Work effectively at the workplace

Unit 3.1 Effective Communication and Coordination of work

Unit 3.2 Work Effectively and Maintain discipline at work.

Unit 3.3 Maintain social diversity at work



Key Learning Outcomes

By the end of this module, participants will be able to:

1. State the importance of work ethics and workplace etiquette.
2. State the importance of effective communication and interpersonal skills.
3. Explain ways to maintain discipline in the workplace.
4. Discuss the common reasons for interpersonal conflict and ways of managing them effectively.

UNIT 3.1: Effective Communication and Coordination at Work

Unit Objectives

By the end of this unit, participants will be able to:

1. Work effectively at the workplace.
2. Demonstrate practices related to gender and PwD sensitization.

3.1.1 Importance of Work Ethics and Workplace Etiquette

Workplace ethics are a set of moral and legal guidelines that organizations follow. These guidelines influence the way customers and employees interact with an organization. Workplace ethics essentially guide how an organization serves its clients and treats its employees.

For example, if a company seeks to fulfil the promises it makes, it may develop processes and set up a robust support system to address this policy and build customer/client loyalty. To achieve this goal, the company may implement specific incentive programs for employees to encourage them to produce high-quality work and ensure the organization fulfils the promises it makes to its clients/ customers.

Many organizations, often the large ones, set detailed ethical codes to guide their operations and control how the organizational processes impact the stakeholders. These ethics usually help organizations maintain certain standards of responsibility, accountability, professionalism and among others, as they navigate through different challenges and day-to-day circumstances. By following these guidelines, organizations often experience several benefits that improve the lives of stakeholders, such as customers, employees, leaders, etc.

Examples of Common Workplace Ethics



Fig. 3.1.1 Examples of Common Workplace Ethics

Workplace ethics are essential for a successful organization with a satisfied and loyal team. High ethical standards help in ensuring all stakeholders, such as customers, investors, employees, and other individuals involved in the workplace operations, feel the organization is safeguarding their interests. By creating and implementing ethical guidelines, organizations can keep the best interests of their employees in mind while maintaining a positive influence on those they impact through their processes.

As a result, employees maintain the organization's best interests by being ethical in their daily work duties. For example, fairly-treated employees of an organization who understand the organization's commitments to environmental sustainability are usually less likely to behave in a manner that causes harm to the environment. Thus, they help maintain a positive public image of the organization. It means that workplace ethics help in maintaining reciprocal relationships that benefit organizations at large and the individuals associated with and influenced by the organizational policies.

Benefits of Workplace Ethics

There are various benefits of implementing workplace ethics. When organizations hold themselves to high ethical standards, leaders, stakeholders, and the general public can experience significant improvements. Following are some of the key benefits of employing ethics in the workplace:



Fig. 3.1.2 Benefits of Workplace Ethics

3.1.2 Interpersonal Communication

Interpersonal communication is a process that involves sharing ideas and emotions with another person, both - verbally and non-verbally. It is essential to interact effectively with others in both personal and professional lives. In professional life or the workplace, strong interpersonal skills play a crucial role in achieving effective collaboration with colleagues.

Interpersonal Skills

Interpersonal skills, in other terms, are known as people skills, which are used to communicate and interact with others effectively. These are soft skills one uses to communicate with others and understand them. One uses these skills in daily life while interacting with people.

Examples of Interpersonal Skills



Fig 3.1.3 Examples of Interpersonal Skills

Numerous interpersonal skills involve communication. Communication can be verbal, such as persuasion or tone of voice — or non-verbal, such as listening and body language.

Importance of Interpersonal Skills

Interpersonal skills are essential for communicating and collaborating with groups and individuals in both personal and professional life. People with strong interpersonal skills often are able to build good relationships and also tend to work well with others. Most people often enjoy working with co-workers who have good interpersonal skills.

Among other benefits of good interpersonal skills is the ability to solve problems and make the best decisions. One can use the ability to understand others and good interpersonal communication skills to find the best solution or make the best decisions in the interest of everyone involved. Strong interpersonal skills help individuals work well in teams and collaborate effectively. Usually, people who possess good interpersonal skills also tend to be good leaders, owing to their ability to communicate well with others and motivate the people around them.

Interpersonal communication is the key to working in a team environment and working collectively to achieve shared goals. Following are the interpersonal communication skills that vital for success at work:

Verbal Communication

The ability to speak clearly, appropriately and confidently can help one communicate effectively with others. It is vital to select the appropriate vocabulary and tone for the target audience.

For example – one should speak formally and professionally in the work environment, while informal language is acceptable in an intimate environment with close friends and family. Also, one should avoid using complex or technical language while communicating with an audience that may not be familiar with it. Using simple language in a courteous tone helps achieve better communication, irrespective of the audience.

Active Listening

Active listening is defined as the ability to pay complete or undivided attention to someone when they speak and understand what they are saying. It is important for effective communication because without understanding what the speaker is saying, it becomes difficult to carry forward a conversation. One should ensure to use appropriate verbal and non-verbal responses, e.g. eye contact, nodding, or smiling, to show interest in what the speaker says. Active listening is also about paying attention to the speaker's body language and visual cues. Asking and answering questions is one of the best ways to demonstrate an interest in conversing with the other person.

Active listening is critical for communicating effectively without ambiguity. It helps one understand the information or instructions being shared. It may also encourage co-workers to share their ideas, which ultimately helps achieve collaboration.

Body Language

One's expression, posture, and gestures are as important as verbal communication. One should practice open body language to encourage positivity and trust while communicating. Open body language includes - maintaining eye contact, nodding, smiling and being comfortable. On the other hand, one should avoid closed body language, e.g. crossed arms, shifting eyes and restless behaviour.

Empathy

Empathy is the ability to understand the emotions, ideas and needs of others from their point of view. Empathy is also known as emotional intelligence. Empathetic people are good at being aware of others' emotions and compassionate when communicating with them. Being empathetic in the workplace can be good to boost the morale of employees and improve productivity. By showing empathy, one can gain the trust and respect of others.

Conflict Resolution

One can use interpersonal communication skills to help resolve disagreements and conflicts in the workplace. This involves the application of negotiation and persuasion skills to resolve arguments between conflicting parties. It is also important to evaluate and understand both sides of the argument by listening closely to everyone involved and finding an amicable solution acceptable to all.

Teamwork

Employees who communicate and work well in a team often have better chances of achieving success and common goals. Being a team player can help one avoid conflicts and improve productivity. One can do this by offering to help co-workers when required and asking for their feedback and ideas. When team members give their opinions or advice, one should positively receive and react to the opinions/advice. One should be optimistic and encouraging when working in groups.

Improving Interpersonal Skills

One can develop interpersonal skills by practising good communication and setting goals for improvement. One should consider the following tips to improve their interpersonal skills:

- One should ask for feedback from co-workers, managers, family or friends to figure out what needs improvement concerning their interpersonal skills.
- One can identify the areas of interpersonal communication to strengthen by watching others.
- One can learn and improve interpersonal skills by observing co-workers, company leaders and professionals who possess good interpersonal skills. This includes watching and listening to them to note how they communicate and the body language used by them. It is vital to note their speed of speaking, tone of voice, and the way they engage with others. One should practice and apply such traits in their own interactions and relationships.
- One should learn to control their emotions. If stressed or upset, one should wait until being calm to have a conversation. One is more likely to communicate effectively and confidently when not under stress.
- One can reflect on their personal and professional conversations to identify the scope of improvement and learn how to handle conversations better or communicate more clearly. It helps to consider whether one could have reacted differently in a particular situation or used specific words or positive body language more effectively. It is also vital to note the successful and positive interactions to understand why they are successful.
- One should practice interpersonal skills by putting oneself in positions where one can build relationships and use interpersonal skills. For example, one can join groups that have organized meetings or social events. These could be industry-specific groups or groups with members who share an interest or hobby.
- Paying attention to family, friends and co-workers and making efforts to interact with them helps a lot. One should complement their family, friends and co-workers on their good ideas, hard work and achievements. Trying to understand someone's interests and showing interest in knowing them can help one build strong interpersonal skills. Offering to help someone, especially in difficult situations, helps build stronger and positive workplace relationships.
- One should avoid distractions, such as a mobile phone, while interacting with someone. Giving someone full attention while avoiding distractions helps achieve a clear exchange of ideas. By listening with focus, one can understand and respond effectively.

- One can attend appropriate courses on interpersonal skills or sign up for workshops at work to improve interpersonal skills. One can find many resources online also, such as online videos.
- For personal mentoring, one can approach a trusted family member, friend, co-worker, or current/former employer. A person one looks up to with respect and admires is often a good choice to be selected as a mentor. One can even hire a professional career or communication coach.

Interpersonal communication skills often help one boost their morale, be more productive in the workplace, complete team projects smoothly and build positive and strong relationships with co-workers.

Good conflict resolution skills can help one contribute to creating a collaborative and positive work environment. With the ability to resolve conflicts, one can earn the trust and respect of co-workers.

UNIT 3.2: Working Effectively and Maintaining Discipline at Work

Unit Objectives

By the end of this unit, participants will be able to:

1. Discuss the importance of following organizational guidelines for dress code, time schedules, language usage and other behavioural aspects.
2. Explain the importance of working as per the workflow of the organization to receive instructions and report problems.
3. Explain the importance of conveying information/instructions as per defined protocols to the authorised persons/team members.
4. Explain the common workplace guidelines and legal requirements on non-disclosure and confidentiality of business-sensitive information.
5. Describe the process of reporting grievances and unethical conduct such as data breaches, sexual harassment at the workplace, etc.
6. Discuss ways of dealing with heightened emotions of self and others.

3.2.1 Discipline at Work

Discipline is essential for organizational success. It helps improve productivity, reduce conflict and prevent misconduct in the workplace. It is important to have rules concerning workplace discipline and ensure that all employees comply with them. In the absence of discipline, a workplace may experience conflicts, bullying, unethical behaviour and poor employee performance. An efficient workplace disciplinary process helps create transparency in the organization. Benefits of disciplinary standards:

All employees follow the same rules which helps establish uniformity and equality in the workplace

Managers and supervisors have defined guidelines on what action to take while initiating disciplinary action

With well-defined and enforced disciplinary rules, an organization can avoid various safety, security, reputational risks

Fig 3.2.1 Benefits of Disciplinary Standards

Maintaining an organized and cohesive workforce requires maintaining discipline in both personal and professional behaviour. It is important to follow the appropriate measures to keep employees in line without affecting their morale.

Defining Discipline

The first and crucial step in maintaining workplace discipline is to define what is meant by discipline. It helps to evaluate common discipline problems and devise guidelines for handling them effectively.

Among a number of areas, discipline usually covers:

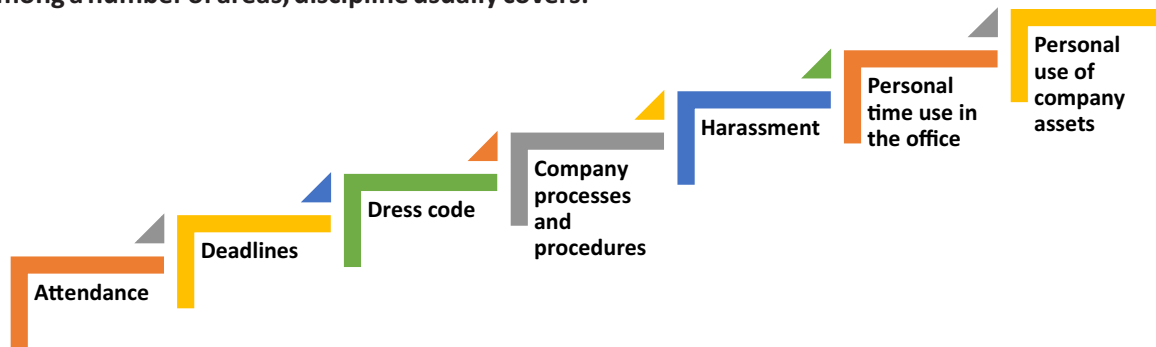


Fig 3.2.2 Examples of Workplace Discipline

According to demography and local issues, it may also include substance use and related issues.

It is vital for a workplace to have an employee handbook or company policy guide, to serve as a rulebook for employees to follow. The employee handbook/ company policy guide should be reviewed and updated periodically according to any issues or areas, or concerns identified concerning workplace discipline. Such manuals should also cover all the laws and regulations governing workplace behaviour.

Defining and documenting workplace rules aids in their implementation, ensuring little or no ambiguity. All employees in a workplace should also have easy access to the workplace guidelines so that they can refer to them to get clarity whenever required. To maintain discipline at work, it is also critical to ensure uniform application of workplace guidelines to all employees without exception.

3.2.2 Employee Code of Conduct

The employee code of conduct manual serves as a guide for employees to inform them regarding the behaviour expected from them at work. It helps create a good work environment with consistent behaviour from employees. The manual should list examples of acceptable and not acceptable behaviours at work. The code of conduct should be discussed with employees so that they have the clarifications required.

For example, an organization may create guidelines concerning the conduct with clients to ensure no contact is made with them except for business purposes, also prescribing the use of appropriate means of communication.

Employees should have a clear understanding concerning their job responsibilities and the behaviour expected from them with all stakeholders, e.g. company personnel, clients and associated third parties. It is critical to have documented guidelines for employees to follow concerning all aspects of work.

It should also document the disciplinary action to be followed in case of non-compliance, e.g. verbal and then written warning, temporary suspension or eventual termination of service in case of repeated non-compliance with the employee code of conduct. Employees should know what the company rules are and what will happen if they break the rules. However, disciplinary action should be initiated only when reasonably required to avoid its misuse for employee harassment.

There should also be an effective mechanism for employees to raise their concerns/ grievances and have them addressed while maintaining privacy, as required, e.g. raising concerns regarding the behaviour of a co-worker.

The employee code of conduct manual must be duly reviewed and approved by the concerned stakeholders, such as the Human Resources (HR) department and company executives.

3.2.3 Interpersonal Conflicts

Interpersonal conflict is any type of conflict between two or more people. These are found in both - personal and professional relationships - among friends, family, and co-workers. In the workplace, interpersonal conflict is often observed when a person or group of people interfere with another person's attempts at completing assignments and achieving goals. It is critical to resolve conflicts in the workplace to boost the morale of employees, repair working relationships among them, and improve customer satisfaction.

Reasons for Workplace Conflicts

Workplace conflicts are often observed when two or more people have different points of view. This can happen between managers, co-workers, or clients and customers. In general, interpersonal conflicts are caused by a lack of communication or unclear communication.

Some of the leading reasons for workplace conflicts are:

- Difference in values
- Personality clashes
- Poor communication

Example of poor communication – if a manager reassigns a task to another employee without communicating with the employee to whom it was originally assigned, interpersonal conflict can arise among them. This may potentially make the first employee, i.e. who was originally assigned the task, feel slighted and mistrusted by the manager. It may even cause animosity in the first employee toward the employee who has now been assigned the task.

Types of Interpersonal Conflict

Following are the four types of interpersonal conflicts:

1. Policy-related interpersonal conflict

When a conflict relates to a decision or situation that involves both parties, it can be called a policy-related interpersonal conflict. Example – two people or groups working on the same project, trying to adopt different approaches. To resolve policy-related interpersonal conflicts, the parties involved should try to look for a win-win situation or make a compromise. This is especially critical to resolve trivial issues so that work is not affected and common goals are achieved.

2. Pseudo-conflicts

Pseudo-conflict arises when two people or groups want different things and cannot reach an agreement. Pseudo-conflicts usually involve trivial disagreements that tend to hide the root of the issue.

3. Ego-related interpersonal conflicts

In ego conflicts, losing the argument may hurt or damage a person's pride. Sometimes ego conflicts arise when a number of small conflicts pile up on being left unresolved. To resolve ego-related conflicts, it's best to find the root of the issue and work towards a resolution.

4. Value-related interpersonal conflicts

Sometimes conflicts may occur between people when they have different value systems. Such conflicts can be difficult to identify initially, making the people involved think the other party is being disagreeable or stubborn, wherein they just have different values. Some co-workers may highly value their personal/ family time after office that they may be unreachable to clients during non-office hours, while others may place a high value on client satisfaction and may still be available for clients during non-office hours. Conflict may arise among such people when they may be required to coordinate to help a client during after-office hours. Value-related interpersonal conflicts are often difficult to settle since neither party likes to compromise.

Resolving Interpersonal Conflicts

Conflicts are usually likely in the workplace; they can, however, be prevented. Often resolving interpersonal conflicts through open communication helps build a stronger relationship, paving the way for effective coordination and success. Some ways to resolve interpersonal conflict:

- **Communication:** A great way to resolve interpersonal conflicts is for the opposing parties to listen to one another's opinions and understand their viewpoints. Meeting in person and keeping the conversation goal-oriented is important. One can have effective communication by following some measures, e.g. staying on the topic, listening actively, being mindful of the body language, maintaining eye contact, etc.

- **Active Listening:** One should patiently listen to what the other person is saying without interrupting or talking over them. It helps one display empathy and get to the root of the issue. Asking questions to seek clarification when required helps in clear communication and conveys to the other person that one is listening to them. Practising active listening is a great way to improve one's communication skills.
- **Displaying Empathy:** Listening attentively and identifying the anxieties/ issues of co-workers is a great way to show empathy and concern. It is essential to understand their feelings and actions to encourage honesty and avoid future conflict.
- **Not Holding Grudges:** With different types of people and personalities in a workplace, it is common for co-workers to have conflicts. It is best to accept the difference in opinions and move on. Being forgiving and letting go of grudges allows one to focus on the positive side of things and perform better at work.

Work-related interpersonal conflicts can be complicated because different people have different leadership styles, personality characteristics, job responsibilities and ways in which they interact. One should learn to look above interpersonal conflicts, resolving them to ensure work goals and environment are not affected.

3.2.4 Importance of Following Organizational Guidelines

Policies and procedures or organizational guidelines are essential for any organization. These provide a road map for the operations of the organization. These are also critical in ensuring compliance with the applicable laws and regulations by guiding the decision-making process and business operations.

Organizational guidelines help bring uniformity to the operations of an organization, which helps reduce the risk of unwanted and unexpected events. These determine how employees are supposed to behave at work, which ultimately helps the business achieve its objectives efficiently.

However, organizational guidelines are ineffective and fail to serve their purpose if they are not followed. Many people don't like the idea of following and abiding by specific guidelines. Such people should be made to understand the benefits of following the organizational guidelines. Some of the key benefits are given below:

With well-defined organizational guidelines in place, no individual can act arbitrarily, irrespective of their position in the organization. All individuals will know the pros and cons of taking certain actions and what to expect in case of unacceptable behaviour. Benefits of following organizational guidelines:

- **Consistent processes and structures:** Organization guidelines help maintain consistency in operations, avoiding any disorder. When all employees follow the organizational guidelines, an organization can run smoothly. These ensure that people in different job roles operate as they are supposed to, knowing what they are responsible for, what is expected of them, and what they can expect from their supervisors and co-workers. With clarity in mind, they can do their jobs with confidence and excellence. With every person working the way intended, it's easy to minimise errors.

With all the staff following organizational guidelines, the organization has a better scope of using time and resources more effectively and efficiently. This allows the organization to grow and achieve its objectives.

- **Better quality service:** By following organizational guidelines, employees perform their duties correctly as per the defined job responsibilities. It helps enhance the quality of the organization's products and services, helping improve the organization's reputation. Working with a reputable organization, employees can take pride in their work and know they are contributing to the reputation.
- **A safer workplace:** When all employees follow organizational guidelines, it becomes easy to minimise workplace incidents and accidents. It reduces the liabilities associated with risks for the organization and limits the interruptions in operations. Employees also feel comfortable and safe in the workplace, knowing their co-workers are ensuring safety at work by following the applicable guidelines.

Different organizations may have different guidelines on dress code, time schedules, language usage, etc. For example – certain organizations in a client-dealing business requiring employees to meet clients personally follow a strict dress code asking their employees to wear formal business attire. Similarly, organizations operating in specific regions may require their employees to use the dominant regional language of the particular region to build rapport with customers and serve them better. Certain organizations, such as banks, often give preference to candidates with knowledge of the regional language during hiring.

Working hours may also differ from one organization to another, with some requiring employees to work extra compared to others. One should follow the organizational guidelines concerning all the aspects of the employment to ensure a cohesive work environment.

3.2.5 Workflow

Workflow is the order of steps from the beginning to the end of a task or work process. In other words, it is the way a particular type of work is organised or the order of stages in a particular work process.

Workflows can help simplify and automate repeatable business tasks, helping improve efficiency and minimise the room for errors. With workflows in place, managers can make quick and smart decisions while employees can collaborate more productively.

Other than the order that workflows create in a business, these have several other benefits, such as:

- **Identifying Redundancies:** Mapping out work processes in a workflow allows one to get a clear, top-level view of a business. It allows one to identify and remove redundant or unproductive processes.

Workflow gives greater insights into business processes. Utilizing such useful insights, one can improve work processes and the bottom line of the business. In many businesses, there are many unnecessary and redundant tasks that take place daily. Once an organization has insight into its processes while preparing workflow, it can determine which activities are really necessary.

Identifying and eliminating redundant tasks creates value for a business. With redundant tasks and processes eliminated, an organization can focus on what's important to the business.

- **Increase in Accountability and Reduction in Micromanagement:** Micromanagement often causes problems in a business setting as most employees don't like being micromanaged, and even many managers don't like the practice. Micromanagement is often identified as one of the reasons why people quit their job.

However, the need for micromanagement can be minimized by clearly mapping out the workflow. This way, every individual in a team knows what tasks need to be completed and by when and who is responsible for completing them. This makes employees more accountable also.

With clearly defined workflow processes, managers don't have to spend much time micromanaging their employees, who don't have to approach the manager to know what the further steps are. Following a workflow, employees know what is going on and what needs to be done. This, in turn, may help increase the job satisfaction of everyone involved while improving the relationships between management and employees.

- **Improved Communication:** Communication at work is critical because it affects all aspects of an organization. There are instances when the main conflict in an organization originates from miscommunication, e.g. the management and employees disagreeing on an aspect, despite pursuing the same objectives. Poor communication is a common workplace issue that is often not dealt with.

This highlights why workflow is important. Workplace communication dramatically can increase with the visibility of processes and accountability. It helps make the daily operations smoother overall.

- **Better Customer Service:** Customers or clients are central to a business. Therefore, it is imperative to find and improve ways to improve customer experience. Relying on outdated manual systems may cause customer requests or complaints to be overlooked, with dissatisfied customers taking their business elsewhere. However, following a well-researched and defined workflow can help improve the quality of customer service.

By automating workflows and processes, an organization can also reduce the likelihood of human error. This also helps improve the quality of products or services over time, resulting in a better customer experience.

3.2.6 Following Instructions and Reporting Problems

All organizations follow a hierarchy, with most employees reporting to a manager or supervisor. For organizational success, it is vital for employees to follow the instructions of their manager or supervisor. They should ensure they perform their duties as per the given instructions to help achieve the common objectives of the organization and deliver quality service or products. This consequently helps maintain the reputation of the organization.

It is also important to be vigilant and identify problems at work or with the organizational work processes. One should deal with the identified within their limits of authority and report out of authority problems to the manager/ supervisor or the concerned person for a prompt resolution to minimise the impact on customers/clients and business.

3.2.7 Information or Data Sharing

Information or data is critical to all organizations. Depending on the nature of its business, an organization may hold different types of data, e.g. personal data of customers or client data concerning their business operations and contacts. It is vital to effective measures for the appropriate handling of different types of data, ensuring its protection from unauthorized access and consequent misuse.

One should access certain data only if authorised to do so. The same is applicable when sharing data which must be shared only with the people authorised to receive it to use it for a specific purpose as per their job role and organizational guidelines. For example – one should be extra cautious while sharing business data with any third parties to ensure they get access only to the limited data they need as per any agreements with them. It is also critical to monitor how the recipient of the data uses it, which should strictly be as per the organizational guidelines. It is a best practice to share appropriate instructions with the recipient of data to ensure they are aware of the purpose with which data is being shared with them and how they are supposed to use and handle it. Any misuse of data must be identified and reported promptly to the appropriate person to minimise any damage arising out of data misuse.

These days most organizations require their employees and business partners or associated third parties to sign and accept the relevant agreement on the non-disclosure of business-sensitive information. In simple terms, business-sensitive information is confidential information. It is proprietary business information collected or created during the course of conducting business, including information about the business, e.g. proposed investments, intellectual property, trade secrets, or plans for a merger and information related to its clients. Business-sensitive information may sometimes also include information regarding a business's competitors in an industry.

The release of business: Sensitive information to competitors or the general public poses a risk to a business. For example, information regarding plans for a merger could be harmful to a business if a competitor gets access to it.

3.2.8 Reporting Issues at Work

Most organizations have defined guidelines on appropriate reporting processes to be followed for reporting different types of issues. For example – one can report any grievances or dissatisfaction concerning co-workers to their manager/supervisor, e.g. data breaches or unethical conduct. If the concern is not addressed, then the employee should follow the organizational guidelines and hierarchy for the escalation of such issues that are not addressed appropriately.

For example: Any concern related to sexual harassment at the workplace should be escalated to the concerned spokesperson, such as Human Resources (HR) representative, and if not satisfied with the action taken, it should be reported to the senior management for their consideration and prompt action.

3.2.9 Dealing with Heightened Emotions

Humans are emotional beings. There may be occasions when one is overwhelmed by emotions and is unable to suppress them. However, there may be situations when one must manage emotions well, particularly at work.

Stress in one's personal and professional life may often cause emotional outbursts at work. Managing one's emotions well, particularly the negative ones, is often seen as a measure of one's professionalism. Anger, dislike, frustration, worry, and unhappiness are the most common negative emotions experienced at work.

Ways to manage negative emotions at work:

- **Compartmentalisation:** It's about not confining emotions to different aspects of one's life. For example, not letting negative emotions from personal life affect work-life and vice versa. One should try to leave personal matters and issues at home. One should train their mind to let go of personal matters before reaching work. Similarly, one can compartmentalise work-related stresses so that negative emotions from work don't affect one's personal life.

- **Deep breathing and relaxation:** Deep breathing helps with anxiety, worry, frustration and anger. One should take deep breaths, slowly count to ten - inhaling and exhaling until one calms down. One can also take a walk to calm down or listen to relaxing music. Talking to someone and sharing concerns also helps one calm down.
- **The 10-second rule:** This is particularly helpful in controlling anger and frustration. When one feels their temper rising, they should count to 10 to calm down and recompose. If possible, one should move away to allow temper to come down.
- **Clarify:** It is always good to clarify before reacting, as it may be a simple case of misunderstanding or miscommunication.
- **Physical activity:** Instead of losing temper, one should plan to exercise, such as running or going to the gym, to let the anger out. Exercise is also a great way to enhance mood and release any physical tension in the body.
- **Practising restraint:** One should avoid replying or making a decision when angry, not allowing anger or unhappiness to cloud one's judgement. It may be best to pause any communication while one is angry, e.g. not communicating over email when angry or upset.
- **Knowing one's triggers:** It helps when one is able to recognise what upsets or angers them. This way, one can prepare to remain calm and plan their reaction should a situation occur. One may even be able to anticipate the other party's reaction.
- **Be respectful:** One should treat their colleagues the same way one would like to be treated. If the other person is rude, one need not reciprocate. It is possible to stay gracious, firm and assertive without being aggressive. Sometimes, rude people back away when they don't get a reaction from the person they are arguing with.
- **Apologise for any emotional outburst:** Sometimes, one can get overwhelmed by emotions, reacting with an emotional outburst. In such a case, one should accept responsibility and apologise immediately to the affected persons without being defensive.
- **Doing away with negative emotions:** It is recommended to let go of anger, frustration and unhappiness at the end of every workday. Harboring negative emotions affects one emotionally, affecting their job performance also. Engaging in enjoyable activities after work is a good stress reliever.

Notes



UNIT 3.3: Maintaining Social Diversity at Work

Unit Objectives

By the end of this unit, participants will be able to:

1. Explain the concept and importance of gender sensitivity and equality.
2. Discuss ways to create sensitivity for different genders and Persons with Disabilities (PwD).

3.3.1 Gender Sensitivity

Gender sensitivity is the act of being sensitive towards people and their thoughts regarding gender. It ensures that people know the accurate meaning of gender equality, and one's gender should not be given priority over their capabilities.



Fig 3.3.1 Gender Equality

Women are an important source of labour in many sectors, yet they have limited access to resources and benefits. Women should receive the same benefits and access to resources as men. A business can improve its productivity and quality of work by providing better support and opportunities to women.

Important Terms:

- **Gender Sensitivity:** Gender sensitivity is the act of being sensitive to the ways people think about gender.
- **Gender Equality:** It means persons of any gender enjoy equal opportunities, responsibilities, and rights in all areas of life.
- **Gender Discrimination:** It means treating an individual unequally or disadvantageously based on their gender, e.g. paying different wages to men and women for similar or equal job positions.

Strategies for Enhancing Gender Equity

To enhance gender equity, one should:

- Follow gender-neutral practices at all levels at work.
- Participate together in decision-making.
- Help in promoting women's participation in different forums.
- Assist women in getting exposure to relevant skills and practices.
- Assist women in capacity building by mentoring, coaching or motivating them, as appropriate.
- Assist in the formation and operation of women support groups.
- Assist in the implementation of women-centric programmes.
- Combine technical training with reproductive health and nutrition for coffee farming households.
- Assist in making a work environment that is healthy, safe, and free from discrimination.

Bridging Gender Differences

Men and women react and communicate very differently. Thus, there are some work differences as both genders have their style and method of handling a situation.

Although, understanding and maturity vary from person to person, even between these genders, based on their knowledge, education, experience, culture, age, and upbringing, as well as how one's brain functions over a thought or problem.

In order to bridge the gap, one should:

- Not categorize all men and women in one way.
- Be aware of the verbal and non-verbal styles of communication of every gender to avoid any miscommunication and work better.
- Be aware of partial behaviour and avoid it.
- Encourage co-workers of different genders to make room by providing space to others.

Ways to reduce Gender Discrimination

- Effective steps against sexual harassment by the concerned authorities and general public.
- Gender stereotypes are how society expects people to act based on their gender. This can only be reduced by adopting appropriate behaviour and the right attitude.
- Objectification of females must be abolished.

Ways to Promote Gender Sensitivity in the Workplace

- Practices that promote gender diversity should be adopted and promoted.
- All genders should receive equal responsibilities, rights, and privileges.
- All genders should have equal pay for similar or the same job roles/ positions.
- Strict and effective workplace harassment policies should be developed and implemented.
- An open-minded and stress-free work environment should be available to all the employees, irrespective of their gender.
- Women should be encouraged to go ahead in every field of work and assume leadership roles.
- Follow appropriate measures for women's empowerment.
- Men should be taught to be sensitive to women and mindful of their rights.

3.3.2 PwD Sensitivity

Some individuals are born with a disability, while others may become disabled due to an accident, illness or as they get old. People with Disabilities (PwD) may have one or more areas in which their functioning is affected. A disability can affect hearing, sight, communication, breathing, understanding, mobility, balance, and concentration or may include the loss of a limb. A disability may contribute to how a person feels and affect their mental health.

Important Terms

- **Persons with Disabilities (PwD):** Persons with Disabilities means a person suffering from not less than 40% of any disability as certified by a medical authority.
- **Types of Disability:**
 - a. Blindness – Visually impaired
 - b. Low Vision
 - c. Leprosy Cured
 - d. Hearing impairment
 - e. Locomotor disability
 - f. Mental retardation
 - g. Mental illness

PwD Sensitivity: PwD sensitivity promotes empathy, etiquette and equal participation of individuals and organizations while working with individuals with a disability, e.g. sensory, physical or intellectual.

Ways to be PwD Sensitive

To be sensitive to PwD, one should:

- Be respectful to all Persons with Disabilities (PwD) and communicate in a way that reflects PwD sensitivity.
- Always be supportive and kind towards a PwD with their daily chores.
- Be ready to assist a PwD to help them avail of any benefit/ livelihood opportunity/ training or any kind that helps them grow.
- Encourage and try to make things easier and accessible to PwD so that they can work without or with minimum help.
- Protest where feasible and report any wrong act/behaviour against any PwD to the appropriate authority.
- Learn and follow the laws, acts, and policies relevant to PwD.

Appropriate Verbal Communication

As part of appropriate verbal communication with all genders and PwD, one should:

- Talk to all genders and PwD respectfully, maintaining a normal tone of voice with appropriate politeness. It is important to ensure one's tone of voice does not have hints of sarcasm, anger, or unwelcome affection.
- Avoid being too self-conscious concerning the words to use while also ensuring not to use words that imply one's superiority over the other.
- Make no difference between a PwD and their caretaker. Treat PwD like adults and talk to them directly.
- Ask a PwD if they need any assistance instead of assuming they need it and offering assistance spontaneously.

Appropriate Non-verbal Communication

Non-verbal communication is essentially the way someone communicates through their body language.

These include:

- **Facial expressions:** The human face is quite expressive, capable of conveying many emotions without using words. Facial expressions must usually be maintained neutral and should change according to the situation, e.g. smile as a gesture of greeting.
- **Body posture and movement:** One should be mindful of how to sit, stand, walk, or hold their head. For example - one should sit and walk straight in a composed manner. The way one moves and carries self, communicates a lot to others. This type of non-verbal communication includes one's posture, bearing, stance, and subtle movements.

- **Gestures:** One should be very careful with their gestures, e.g. waving, pointing, beckoning, or using one's hands while speaking. One should use appropriate and positive gestures to maintain respect for the other person while being aware that a gesture may have different meanings in different cultures.
- **Eye contact:** Eye contact is particularly significant in non-verbal communication. The way someone looks at someone else may communicate many things, such as interest, hostility, affection or attraction. Eye contact is vital for maintaining the flow of conversation and for understanding the other person's interest and response. One should maintain appropriate eye contact, ensuring not to stare or look over the shoulders. To maintain respect, one should sit or stand at the other person's eye level to make eye contact.
- **Touch:** Touch is a very sensitive type of non-verbal communication. Examples are - handshakes, hugs, pat on the back or head, gripping the arm, etc. A firm handshake indicates interest, while a weak handshake indicates the opposite. One should be extra cautious not to touch others inappropriately and avoid touching them inadvertently by maintaining a safe distance.

Rights of PwD

PwD have the right to respect and human dignity. Irrespective of the nature and seriousness of their disabilities, PwD have the same fundamental rights as others, such as:

- Disabled persons have the same civil and political rights as other people
- Disabled persons are entitled to the measures designed to enable them to become as self-dependent as possible
- Disabled persons have the right to economic and social security
- Disabled persons have the right to live with their families or foster parents and participate in all social and creative activities.
- Disabled persons are protected against all exploitation and treatment of discriminatory and abusive nature.

Making Workplace PwD Friendly

- One should not make PwD feel uncomfortable by giving too little or too much attention
- One should use a normal tone while communicating with a PwD and treat them as all others keeping in mind their limitations and type of disability
- Any help should be provided only when asked for by a PwD
- One should help in ensuring the health and well-being of PwD.

Expected Employer Behaviour

Some of the common behavioural traits that employees expect from their employers are:

- **Cooperation:** No work is successful without cooperation from the employer's side. Cooperation helps to understand the job role better and complete it within the given timeline.
- **Polite language:** Polite language is always welcomed at work. This is a basic aspect that everybody expects.
- **Positive Attitude:** Employers with a positive attitude can supervise the work of the employees and act as a helping hand to accomplish the given task. A person with a positive attitude looks at the best qualities in others and helps them gain success.
- **Unbiased behaviour:** Employers should always remain fair towards all their employees. One should not adopt practices to favour one employee while neglecting or ignoring the other. This might create animosity among co-workers.
- **Decent behaviour:** The employer should never improperly present oneself before the employee. One should always respect each other's presence and behave accordingly. The employer should not speak or act in a manner that may make the employee feel uneasy, insulted, and insecure.

Exercise

1. List down three examples of workplace ethics.
 2. List down three examples of interpersonal skills.
 3. Identify two reasons for workplace conflicts.
 4. Identify two ways of resolving interpersonal conflicts.
 5. List down two ways of dealing with heightened emotions at work.
 6. List down two types of non-verbal communication.
4. Basic Health and Safety Practices.

4. Apply health and safety practices at the workplace



- Unit 4.1** Workplace Hazards
- Unit 4.2** Fire Safety
- Unit 4.3** First Aid
- Unit 4.4** Waste Management



Key Learning Outcomes

By the end of this module, participants will be able to:

1. Discuss job-site hazards, risks and accidents.
2. Explain the organizational safety procedures for maintaining electrical safety, handling tools and hazardous materials.
3. Describe how to interpret warning signs while accessing sensitive work areas.
4. Explain the importance of good housekeeping.
5. Describe the importance of maintaining appropriate postures while lifting heavy objects.
6. List the types of fire and fire extinguishers.
7. Describe the concept of waste management and methods of disposing of hazardous waste.
8. List the common sources of pollution and ways to minimize them.
9. Elaborate on electronic waste disposal procedures.
10. Explain how to administer appropriate first aid to victims in case of bleeding, burns, choking, electric shock, poisoning and also administer first aid to victims in case of a heart attack or cardiac arrest due to electric shock.

UNIT 4.1: Workplace Hazards

Unit Objectives

By the end of this unit, participants will be able to:

1. Discuss job-site hazards, risks and accidents.
2. Explain the organizational safety procedures for maintaining electrical safety, handling tools and hazardous materials.
3. Describe how to interpret warning signs while accessing sensitive work areas.
4. Explain the importance of good housekeeping.
5. Describe the importance of maintaining appropriate postures while lifting heavy objects.
6. Explain safe handling of tools and Personal Protective Equipment to be used.

4.1.1 Workplace Safety

Workplace safety is important to be established for creating a safe and secure working for the workers. The workplace has to be administered as per the rules of the Occupational Safety and Health Administration (OSHA). It refers to monitoring the working environment and all hazardous factors that impact employees' safety, health, and well-being. It is important to provide a safe working environment to the employees to increase their productivity, wellness, skills, etc.

The benefits of workplace safety are:

- Employee retention increases if they are provided with a safe working environment.
- Failure to follow OSHA's laws and guidelines can result in significant legal and financial consequences.
- A safe environment enables employees to stay invested in their work and increases productivity.
- Employer branding and company reputation can both benefit from a safe working environment.

4.1.2 Workplace Hazards

A workplace is a situation that has the potential to cause harm or injury to the workers and damage the tools or property of the workplace. Hazards exist in every workplace and can come from a variety of sources. Finding and removing them is an important component of making a safe workplace.

Common Workplace Hazards

The common workplace hazards are:

- **Biological:** The threats caused by biological agents like viruses, bacteria, animals, plants, insects and also humans, are known as biological hazards.

- **Chemical:** Chemical hazard is the hazard of inhaling various chemicals, liquids and solvents. Skin irritation, respiratory system irritation, blindness, corrosion, and explosions are all possible health and physical consequences of these dangers.
- **Mechanical:** Mechanical Hazards comprise the injuries that can be caused by the moving parts of machinery, plant or equipment.
- **Psychological:** Psychological hazards are occupational hazards caused by stress, harassment, and violence.
- **Physical:** The threats that can cause physical damage to people is called physical hazard. These include unsafe conditions that can cause injury, illness and death.
- **Ergonomic:** Ergonomic Hazards are the hazards of the workplace caused due to awkward posture, forceful motion, stationary position, direct pressure, vibration, extreme temperature, noise, work stress, etc.

Workplace Hazards Analysis

A workplace hazard analysis is a method of identifying risks before they occur by focusing on occupational tasks. It focuses on the worker's relationship with the task, the tools, and the work environment. After identifying the hazards of the workplace, organisations shall try to eliminate or minimize them to an acceptable level of risk.

Control Measures of Workplace Hazards

Control measures are actions that can be taken to reduce the risk of being exposed to the hazard. Elimination, Substitution, Engineering Controls, Administrative Controls, and Personal Protective Equipment are the five general categories of control measures.

- **Elimination:** The most successful control technique is to eliminate a specific hazard or hazardous work procedure or prevent it from entering the workplace.
- **Substitution:** Substitution is the process of replacing something harmful with something less hazardous. While substituting the hazard may not eliminate all of the risks associated with the process or activity, it will reduce the overall harm or health impacts.
- **Engineering Controls:** Engineered controls protect workers by eliminating hazardous situations or creating a barrier between the worker and the hazard, or removing the hazard from the person.
- **Administrative Controls:** To reduce exposure to hazards, administrative controls limit the length of time spent working on a hazardous task that might be used in combination with other measures of control.
- **Personal Protective Equipment:** Personal protective equipment protects users from health and safety hazards at work. It includes items like safety helmets, gloves, eye protection, etc.

4.1.3 Risk for a Drone Technician

A drone technician may require to repair the propeller, motor and its mount, battery, mainboards, processor, booms, avionics, camera, sensors, chassis, wiring and landing gear. A technician may face some risks while repairing the drones' equipment.

- The technician is susceptible to being physically harmed by propellers.
- Direct contact with exposed electrical circuits can injure the person.
- If the skin gets in touch with the heat generated from electric arcs, it burns the internal tissues.
- Major electrical injuries can occur due to poorly installed electrical equipment, faulty wiring, overloaded or overheated outlets, use of extension cables, incorrect use of replacement fuses, use of equipment with wet hands, etc.

4.1.4 Workplace Warning Signs

A Hazard sign is defined as 'information or instruction about health and safety at work on a signboard, an illuminated sign or sound signal, a verbal communication or hand signal.'

There are four different types of safety signs:

- Prohibition / Danger Alarm Signs
- Mandatory Signs
- Warning Signs
- And Emergency

1. Prohibition Signs

A "prohibition sign" is a safety sign that prohibits behaviour that is likely to endanger one's health or safety. The colour red is necessary for these health and safety signs. Only what or who is forbidden should be displayed on a restriction sign.



Fig. 4.1.1. Prohibition Warning Signs

2. Mandatory Signs

Mandatory signs give clear directions that must be followed. The icons are white circles that have been reversed out of a blue circle. On a white background, the text is black.



Fig. 4.1.2. Mandatory Signs

3. Warning Signs

Warning signs are the safety information communication signs. They are shown as a 'yellow colour triangle'.



Fig. 4.1.3. Warning Signs

4. Emergency Signs

The location or routes to emergency facilities are indicated by emergency signs. These signs have a green backdrop with a white emblem or writing. These signs convey basic information and frequently refer to housekeeping, company procedures, or logistics.



Fig. 4.1.4. Emergency Signs

4.1.5 Cleanliness in the Workplace

Workplace cleanliness maintenance creates a healthy, efficient and productive environment for the employees. Cleanliness at the workplace is hindered by some elements like cluttered desks, leftover food, waste paper, etc. A tidy workplace is said to improve employee professionalism and enthusiasm while also encouraging a healthy working environment.

Benefits of cleanliness in the workplace:

1. **Productivity:** Cleanliness in the workplace can bring a sense of belonging to the employees, also motivating and boosting the morale of the employees. This results in increasing their productivity.
2. **Employee Well-being:** Employee well-being can be improved by providing a clean work environment. Employees use fewer sick days in a workplace where litter and waste are properly disposed of, and surfaces are cleaned regularly, resulting in increased overall productivity.
3. **Positive Impression:** Cleanliness and orderliness in the workplace provide a positive impression on both employees and visitors.
4. **Cost saving:** By maintaining acceptable levels of cleanliness in the workplace, businesses can save money on cleaning bills and renovations, which may become necessary if the premises are not properly kept.

Reasons for Cleaning the Workplace

- Cleaning of dry floors, mostly to prevent workplace slips and falls.
- Disinfectants stop bacteria in their tracks, preventing the spread of infections and illness.
- Proper air filtration decreases hazardous substance exposures such as dust and fumes.
- Light fixture cleaning improves lighting efficiency.
- Using environmentally friendly cleaning chemicals that are safer for both personnel and the environment.
- Work environments are kept clean by properly disposing of garbage and recyclable items.

4.1.6 Lifting and Handling of Heavy Loads

Musculoskeletal Injuries (MSIs), such as sprains and strains, can occur while lifting, handling, or carrying objects at work. When bending, twisting, uncomfortable postures and lifting heavy objects are involved, the risk of injury increases. Ergonomic controls can help to lower the risk of injury and potentially prevent it.

Types of injuries caused while lifting heavy objects:

- Cuts and abrasions are caused by rough surfaces.
- Crushing of feet or hands.
- Strain to muscles and joints.

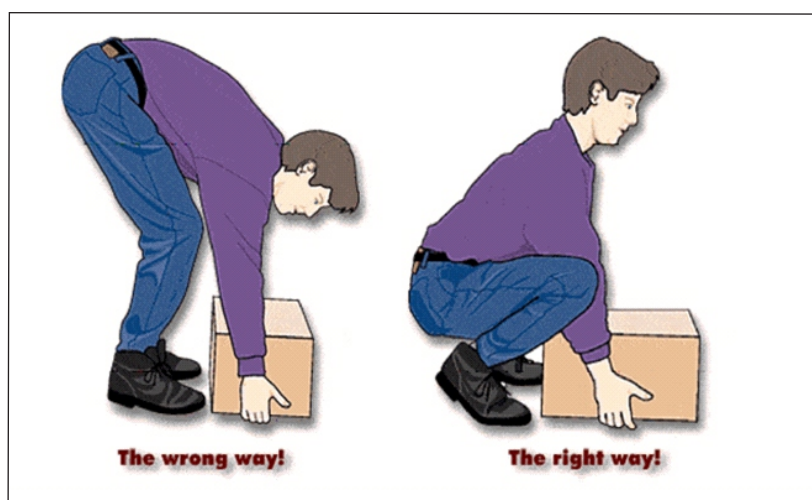


Fig. 4.1.5. Lifting loads technique

Preparing to Lift

A load that appears light enough to bear at first will grow increasingly heavier as one carries it further. The person carrying the weight should be able to see over or around it at all times.



The amount of weight a person can lift, depends on their age, physique, and health.

It also depends on whether or not the person is used to lifting and moving hefty objects.

Common Causes of Back Injuries

The Most Common Causes of Back Injuries are:

1. **Inadequate Training:** The individual raising the load receives no sufficient training or guidance.
2. **Lack of awareness of technique:** The most common cause of back pain is incorrect twisting and posture, which causes back strain.
3. **Load size:** The load size to consider before lifting. If the burden is too much for one’s capacity or handling, their back may be strained and damaged.
4. **Physical Strength:** Depending on their muscle power, various persons have varied physical strengths. One must be aware of their limitations.
5. **Teamwork:** The operation of a workplace is all about working together. When opposed to a single person lifting a load, two people can lift it more easily and without difficulty. If one of two people isn't lifting it properly, the other or both of them will suffer back injuries as a result of the extra strain.

Technique	Demonstration
<p>1. Ensure one has a wide base of support before lifting the heavy object. Ensure one’s feet are shoulder-width apart, and one foot is slightly ahead of the other at all times. This will help one maintain a good balance during the lifting of heavy objects. This is known as the Karate Stance.</p>	
<p>2. Squat down as near to the object as possible when one is ready to lift it, bending at the hips and knees with the buttocks out. If the object is really heavy, one may wish to place one leg on the floor and the other bent at a straight angle in front of them.</p>	

4. By straightening one's hips and knees, slowly elevate the thing (not the back). As one rises, they should extend their legs and exhale. Lift the heavy object without twisting the body or bending forward.



5. Do not lift bending forward.



6. Hold the load close to the body.



7. Never lift heavy objects above the shoulder






7. Never lift heavy objects above the shoulder	
8. Use the feet (not the body) to change direction, taking slow, small steps.	
9. Set down the heavy object carefully, squatting with the knees and hips only.	

Table 4.1.1 Techniques for lifting heavy objects

³Source: <https://www.braceability.com/blogs/articles/7-proper-heavy-lifting-techniques>

4.1.7 Safe Handling of Tools

Workers should be trained on how to use tools safely. When tools are misplaced or handled incorrectly by workers, they can be dangerous. The following are some suggestions from the National Safety Council for safe tool handling when they are not in use:

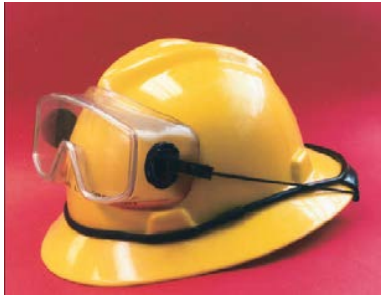


- Never carry tools up or down a ladder in a way that makes it difficult to grip them. Instead of being carried by the worker, tools should be lifted up and down using a bucket or strong bag.
- Tools should never be tossed but should be properly passed from one employee to the next. Pointed tools should be passed with the handles facing the receiver or in their carrier.
- When turning and moving around the workplace, workers carrying large tools or equipment on their shoulders should pay particular attention to clearances.
- Pointed tools such as chisels and screwdrivers should never be kept in a worker's pocket. They can be carried in a toolbox, pointing down in a tool belt or pocket tool bag, or in hand with the tip always held away from the body.

- Tools should always be stored while not in use. People below are put in danger when tools are left sitting around on an elevated structure, such as a scaffold. In situations when there is a lot of vibration, this risk increases.

4.1.8 Personal Protective Equipment

Personal Protective Equipment, or "PPE," is equipment worn to reduce exposure to risks that might result in significant occupational injuries or illnesses. *Chemical, Radiological, Physical, Electrical, Mechanical,* and other job dangers may cause these injuries and diseases.

PPE used for protection from the following injuries are:

Injury Protection	Protection	PPE
Head Injury Protection	Falling or flying objects, stationary objects, or contact with electrical wires can cause impact, penetration, and electrical injuries. Hard hats can protect one's head from these injuries. A common electrician's hard hat is shown in the figure below. This hard hat is made of nonconductive plastic and comes with a set of safety goggles.	
Foot and Leg Injury Protection	In addition to foot protection and safety shoes, leggings (e.g., leather) can guard against risks such as falling or rolling objects, sharp objects, wet and slippery surfaces, molten metals, hot surfaces, and electrical hazards.	
Eye and Face Injury Protection	Spectacles, goggles, special helmets or shields, and spectacles with side shields and face shields can protect against the hazards of flying fragments, large chips, hot sparks, radiation, and splashes from molten metals. They also offer protection from particles, sand, dirt, mists, dust, and glare.	



<p>Protection against Hearing Loss</p>	<p>Hearing protection can be obtained by wearing earplugs or earmuffs. High noise levels can result in permanent hearing loss or damage, as well as physical and mental stress. Self-forming earplugs composed of foam, waxed cotton, or fibreglass wool usually fit well. Workers should be fitted for moulded or prefabricated earplugs by a specialist.</p>	
<p>Hand Injury Protection</p>	<p>Hand protection will aid workers who are exposed to dangerous substances by skin absorption, serious wounds, or thermal burns. Gloves are a frequent protective clothing item. When working on electrified circuits, electricians frequently use leather gloves with rubber inserts. When stripping cable with a sharp blade, Kevlar gloves are used to prevent cuts.</p>	
<p>Whole Body Protection</p>	<p>Workers must protect their entire bodies from risks such as heat and radiation. Rubber, leather, synthetics, and plastic are among the materials used in whole-body PPE, in addition to fire-retardant wool and cotton. Maintenance staff who operate with high-power sources such as transformer installations and motor-control centres are frequently obliged to wear fire-resistant clothes.</p>	

Table 4.1.2 Personal protective equipment

Notes



A large rectangular area with a thin orange border, containing 20 horizontal lines for writing notes.

UNIT 4.2: Fire Safety

Unit Objectives

By the end of this unit, participants will be able to:

1. List the types of fire and fire extinguishers.

4.2.1 Fire Safety

Fire safety is a set of actions aimed at reducing the amount of damage caused by fire. Fire safety procedures include both those that are used to prevent an uncontrolled fire from starting and those that are used to minimise the spread and impact of a fire after it has started. Developing and implementing fire safety measures in the workplace is not only mandated by law but is also essential for the protection of everyone who may be present in the building during a fire emergency.

The basic Fire Safety Responsibilities are:

- To identify risks on the premises, a fire risk assessment must be carried out.
- Ascertain that fire safety measures are properly installed.
- Prepare for unexpected events.
- Fire safety instructions and training should be provided to the employees.

4.2.2 Respond to a Workplace Fire

- Workplace fire drills should be conducted on a regular basis.
- If one has a manual alarm, they should raise it.
- Close the doors and leave the fire-stricken area as soon as possible. Ensure that the evacuation is quick and painless.
- Turn off dangerous machines and don't stop to get personal items.
- Assemble at a central location. Ascertain that the assembly point is easily accessible to the employees.
- If one's clothing catches fire, one shouldn't rush about it. They should stop and descend on the ground and roll to smother the flames if their clothes catch fire.

4.2.3 Fire Extinguisher

Fire extinguishers are portable devices used to put out small flames or minimise their damage until fire-fighters arrive. These are maintained on hand in locations such as fire stations, buildings, workplaces, public transit, and soon. The types and quantity of extinguishers that are legally necessary for a given region are determined by the applicable safety standards.

Types of fire extinguishers are:

There are five main types of fire extinguishers:

1. Water.
2. Powder.
3. Foam.
4. Carbon Dioxide (Co2).
5. Wet chemical.

1. Water: Water fire extinguishers are one of the most common commercial and residential fire extinguishers on the market. They're meant to be used on class-A flames.



2. Powder: The L2 powder fire extinguisher is the most commonly recommended fire extinguisher in the Class D Specialist Powder category, and is designed to put out burning lithium metal fires.



3. Foam: Foam extinguishers are identified by a cream rectangle with the word "foam" printed on it. They're mostly water-based, but they also contain a foaming component that provides a quick knock-down and blanketing effect on flames. It suffocates the flames and seals the vapours, preventing re-ignition.



4. Carbon Dioxide (Co2): Class B and electrical fires are extinguished with carbon dioxide extinguishers, which suffocate the flames by removing oxygen from the air. They are particularly beneficial for workplaces and workshops where electrical fires may occur since, unlike conventional extinguishers, they do not leave any toxins behind and hence minimise equipment damage.



5. **Wet Chemical:** Wet chemical extinguishers are designed to put out fires that are classified as class F. They are successful because they can put out extremely high-temperature fires, such as those caused by cooking oils and fats.



UNIT 4.3: First Aid

Unit Objectives

By the end of this unit, participants will be able to:

1. Explain how to administer appropriate first aid to victims in case of bleeding, burns, choking, electric shock, poisoning.
2. Explain how to administer first aid to victims in case of a heart attack or cardiac arrest due to electric shock.

4.3.1 First Aid

First aid is the treatment or care given to someone who has sustained an injury or disease until more advanced care can be obtained or the person recovers.

The aim of first aid is to:

- Preserve life
- Prevent the worsening of a sickness or injury
- If at all possible, relieve pain
- Encourage recovery
- Keep the unconscious safe.

First aid can help to lessen the severity of an injury or disease, and in some situations, it can even save a person's life.

4.3.2 Need for First Aid at the Workplace

- In the workplace, first aid refers to providing immediate care and life support to persons who have been injured or become unwell at work.
- Many times, first aid can help to lessen the severity of an accident or disease.
- It can also help an injured or sick person relax. In life-or-death situations, prompt and appropriate first aid can make all the difference.

4.3.2 Need for First Aid at the Workplace

In the workplace, first aid refers to providing immediate care and life support to persons who have been injured or become unwell at work.

Many times, first aid can help to lessen the severity of an accident or disease.

It can also help an injured or sick person relax. In life-or-death situations, prompt and appropriate first aid can make all the difference.

4.3.3 Treating Minor Cuts and Scrapes

Steps to keep cuts clean and prevent infections and scars:

- **Wash Hands:** Wash hands first with soap and water to avoid introducing bacteria into the cut and causing an infection. One should use the hand sanitiser if one is on the go.
- **Stop the bleeding:** Using a gauze pad or a clean towel, apply pressure to the wound. For a few minutes, keep the pressure on.
- **Clean Wounds:** Once the bleeding has stopped, clean the wound by rinsing it under cool running water or using a saline wound wash. Use soap and a moist washcloth to clean the area around the wound. Soap should not be used on the cut since it may irritate the skin. Also, avoid using hydrogen peroxide or iodine, as these may aggravate the wound.
- **Remove Dirt:** Remove any dirt or debris from the area. Pick out any dirt, gravel, glass, or other material in the cut with a pair of tweezers cleaned with alcohol.

4.3.4 Heart Attack

When the blood flow carrying oxygen to the heart is blocked, a heart attack occurs. The heart muscle runs out of oxygen and starts to die.

Symptoms of a heart attack can vary from person to person. They may be mild or severe. Women, older adults, and people with diabetes are more likely to have subtle or unusual symptoms.

Symptoms in adults may include:

- Changes in mental status, especially in older adults.
- Chest pain that feels like pressure, squeezing, or fullness. The pain is most often in the centre of the chest. It may also be felt in the jaw, shoulder, arms, back, and stomach. It can last for more than a few minutes or come and go.
- Cold sweat.
- Light-headedness.
- Nausea (more common in women).
- Indigestion.

- Vomiting.
- Numbness, aching or tingling in the arm (usually the left arm, but the right arm may be affected alone, or along with the left).
- Shortness of breath.
- Weakness or fatigue, especially in older adults and in women.

First Aid for Heart Attack

If one thinks someone is experiencing a heart attack, they should:

- Have the person sit down, rest, and try to keep calm.
- Loosen any tight clothing.
- Ask if the person takes any chest pain medicine, such as nitro-glycerine for a known heart condition, and help them take it.
- If the pain does not go away promptly with rest or within 3 minutes of taking nitro-glycerine, call for emergency medical help.
- If the person is unconscious and unresponsive, call 911 or the local emergency number, then begin CPR.
- If an infant or child is unconscious and unresponsive, perform 1 minute of CPR, then call 911 or the local emergency number.

UNIT 4.4: Waste Management

Unit Objectives

By the end of this unit, participants will be able to:

1. Describe the concept of waste management and methods of disposing of hazardous waste.
2. List the common sources of pollution and ways to minimize them.
3. Elaborate on electronic waste disposal procedures.

4.4.1. Waste Management and Methods of Waste Disposal

The collection, disposal, monitoring, and processing of waste materials is known as waste management. These wastes affect living beings' health and the environment. For reducing their effects, they have to be managed properly. The waste is usually in solid, liquid or gaseous form.

The importance of waste management is:

Waste management is important because it decreases waste's impact on the environment, health, and other factors. It can also assist in the reuse or recycling of resources like paper, cans, and glass. The disposal of solid, liquid, gaseous, or dangerous substances is the example of waste management.

When it comes to trash management, there are numerous factors to consider, including waste disposal, recycling, waste avoidance and reduction, and garbage transportation. Treatment of solid and liquid wastes is part of the waste management process. It also provides a number of recycling options for goods that aren't classified as garbage during the process.

4.4.2 Methods of Waste Management

Non-biodegradable and toxic wastes, such as radioactive remains, can cause irreversible damage to the environment and human health if they are not properly disposed of. Waste disposal has long been a source of worry, with population increase and industrialisation being the primary causes. Here are a few garbage disposal options.

- **Landfills:** The most common way of trash disposal today is to throw daily waste/garbage into landfills. This garbage disposal method relies on burying the material in the ground.
- **Recycling:** Recycling is the process of transforming waste items into new products in order to reduce energy consumption and the use of fresh raw materials. Recycling reduces energy consumption, landfill volume, air and water pollution, greenhouse gas emissions, and the preservation of natural resources for future use.

3. **Composting:** Composting is a simple and natural bio-degradation process that converts organic wastes, such as plant remnants, garden garbage, and kitchen waste, into nutrient-rich food for plants.
4. **Incineration:** Incineration is the process of combusting garbage. The waste material is cooked to extremely high temperatures and turned into materials such as heat, gas, steam, and ash using this technology.

4.4.3 Recyclable, Non-Recyclable and Hazardous Waste

1. **Recyclable Waste:** The waste which can be reused or recycled further is known as recyclable waste.
2. **Non-recyclable Waste:** The waste which cannot be reused or recycled is known as non-recyclable waste. Polythene bags are a great example of non-recyclable waste.
3. **Hazardous Waste:** The waste which can create serious harm to the people and the environment is known as hazardous waste.

4.4.4 Sources of Pollution

Pollution is defined as the harm caused by the presence of a material or substances in places where they would not normally be found or at levels greater than normal. Polluting substances might be in the form of a solid, a liquid, or a gas.

- **Point source of pollution:** Pollution from a point source enters a water body at a precise location and can usually be identified. Effluent discharges from sewage treatment plants and industrial sites, power plants, landfill sites, fish farms, and oil leakage via a pipeline from industrial sites are all potential point sources of contamination.

Point source pollution is often easy to prevent since it is feasible to identify where it originates, and once identified, individuals responsible for the pollution can take rapid corrective action or invest in longer-term treatment and control facilities.

- **Diffuse source of pollution:** As a result of land-use activities such as urban development, amenity, farming, and forestry, diffuse pollution occurs when pollutants are widely used and diffused over a large region. These activities could have occurred recently or in the past. It might be difficult to pinpoint specific sources of pollution and, as a result, take rapid action to prevent it because prevention often necessitates significant changes in land use and management methods.

Pollution Prevention

Pollution prevention entails acting at the source of pollutants to prevent or minimise their production. It saves natural resources, like water, by using materials and energy more efficiently.

Pollution prevention includes any practice that:

- Reduces the amount of any hazardous substance, pollutant, or contaminant entering any waste stream or otherwise released into the environment (including fugitive emissions) prior to recycling, treatment, or disposal;
- Reduces the hazards to public health and the environment associated with the release of such substances, pollutants, or contaminants (these practices are known as "source reduction");
- Improved efficiency in the use of raw materials, energy, water, or other resources, or Conservation is a method of safeguarding natural resources.
- Improvements in housekeeping, maintenance, training, or inventory management; equipment or technology adjustments; process or method modifications; product reformulation or redesign; raw material substitution; or improvements in housekeeping, maintenance, training, or inventory control.

4.4.5 Electronic Waste

Lead, cadmium, beryllium, mercury, and brominated flame retardants are found in every piece of electronic waste. When gadgets and devices are disposed of illegally, these hazardous compounds are more likely to contaminate the earth, pollute the air, and leak into water bodies.

When e-waste is dumped in a landfill, it tends to leach trace metals as water runs through it. The contaminated landfill water then reaches natural groundwater with elevated toxic levels, which can be dangerous if it reaches any drinking water bodies. Despite having an environmentally benign approach, recycling generally results in international shipment and dumping of the gadgets in pits.

Some eco-friendly ways of disposing of e-waste are:

- Giving back the e-waste to the electronic companies and drop-off points.
- Following guidelines issued by the government.
- Selling or donating the outdated technology-based equipment.
- Giving e-waste to a certified e-waste recycler.

Exercise

1. Name all five types of fire extinguishers.
2. Explain PPE in brief.
3. List the common workplace hazards.
4. Fill in the Blacks:
 - i. A "_____ sign" is a safety sign that prohibits behaviour that is likely to endanger one's health or safety.
 - ii. _____ entails acting at the source of pollutants to prevent or minimise their production.
 - iii. _____ is the treatment or care given to someone who has sustained an injury or disease until more advanced care can be obtained or the person recovers.
 - iv. The threats caused by biological agents like viruses, bacteria, animals, plants, insects and also humans, are known as _____.
 - v. The workplace has to be administered as per the rules of the _____.

Notes



A large rectangular area with an orange border, containing 25 horizontal lines for writing notes.





5. Employability & Entrepreneurship Skills

- Unit 5.1** Personal Strengths & Value Systems
- Unit 5.2** Digital Literacy: A Recap
- Unit 5.3** Money Matters
- Unit 5.4** Preparing for Employment & Self Employment
- Unit 5.5** Understanding Entrepreneurship
- Unit 5.6** Preparing to be an Entrepreneur



Key Learning Outcomes



By the end of this module, participants will be able to:

1. Explain the meaning of health
2. List common health issues
3. Discuss tips to prevent common health issues
4. Explain the meaning of hygiene
5. Discuss the purpose of Swacch Bharat Abhiyan
6. Explain the meaning of habit
7. Discuss ways to set up a safe work environment
8. Discuss critical safety habits to be followed by employees
9. Explain the importance of self-analysis
10. Discuss motivation with the help of Maslow's Hierarchy of Needs
11. Discuss the meaning of achievement motivation
12. List the characteristics of entrepreneurs with achievement motivation
13. List the different factors that motivate you
14. Discuss the role of attitude in self-analysis
15. Discuss how to maintain a positive attitude
16. List your strengths and weaknesses
17. Discuss the qualities of honest people
18. Describe the importance of honesty in entrepreneurs
19. Discuss the elements of a strong work ethic
20. Discuss how to foster a good work ethic
21. List the characteristics of highly creative people
22. List the characteristics of highly innovative people
23. Discuss the benefits of time management
24. List the traits of effective time managers
25. Describe effective time management technique
26. Discuss the importance of anger management
27. Describe anger management strategies
28. Discuss tips for anger management
29. Discuss the causes of stress
30. Discuss the symptoms of stress
31. Discuss tips for stress management
32. Identify the basic parts of a computer
33. Identify the basic parts of a keyboard
34. Recall basic computer terminology
35. Recall the functions of basic computer keys

36. Discuss the main applications of MS Office
37. Discuss the benefits of Microsoft Outlook
38. Discuss the different types of e-commerce
39. List the benefits of e-commerce for retailers and customers
40. Discuss how the Digital India campaign will help boost e-commerce in India
41. Describe how you will sell a product or service on an e-commerce platform
42. Discuss the importance of saving money
43. Discuss the benefits of saving money
44. Discuss the main types of bank accounts
45. Describe the process of opening a bank account
46. Differentiate between fixed and variable costs
47. Describe the main types of investment options
48. Describe the different types of insurance products
49. Describe the different types of taxes
50. Discuss the uses of online banking
51. Discuss the main types of electronic funds transfers
52. Discuss the steps to prepare for an interview
53. Discuss the steps to create an effective Resume
54. Discuss the most frequently asked interview questions
55. Discuss how to answer the most frequently asked interview questions
56. Discuss basic workplace terminology
57. Discuss the concept of entrepreneurship
58. Discuss the importance of entrepreneurship
59. Describe the characteristics of an entrepreneur
60. Describe the different types of enterprises
61. List the qualities of an effective leader
62. Discuss the benefits of effective leadership
63. List the traits of an effective team
64. Discuss the importance of listening effectively
65. Discuss how to listen effectively
66. Discuss the importance of speaking effectively
67. Discuss how to speak effectively
68. Discuss how to solve problems
69. List important problem solving traits
70. Discuss ways to assess problem solving skills
71. Discuss the importance of negotiation

72. Discuss how to negotiate
73. Discuss how to identify new business opportunities
74. Discuss how to identify business opportunities within your business
75. Explain the meaning of entrepreneur
76. Describe the different types of entrepreneurs
77. List the characteristics of entrepreneurs
78. Recall entrepreneur success stories
79. Discuss the entrepreneurial process
80. Describe the entrepreneurship ecosystem
81. Discuss the government's role in the entrepreneurship ecosystem
82. Discuss the purpose of the Make in India campaign
83. Discuss key schemes to promote entrepreneurs
84. Discuss the relationship between entrepreneurship and risk appetite
85. Discuss the relationship between entrepreneurship and resilience
86. Describe the characteristics of a resilient entrepreneur
87. Discuss how to deal with failure
88. Discuss how market research is carried out
89. Describe the 4 Ps of marketing
90. Discuss the importance of idea generation
91. Recall basic business terminology
92. Discuss the need for CRM
93. Discuss the benefits of CRM
94. Discuss the need for networking
95. Discuss the benefits of networking
96. Discuss the importance of setting goals
97. Differentiate between short-term, medium-term and long-term goals
98. Discuss how to write a business plan
99. Explain the financial planning process
100. Discuss ways to manage your risk
101. Describe the procedure and formalities for applying for bank finance
102. Discuss how to manage your own enterprise
103. List important questions that every entrepreneur should ask before starting an enterprise

UNIT 5.1: Personal Strengths & Value Systems

Unit Objectives



By the end of this unit, participants will be able to:

1. Explain the meaning of health
2. List common health issues
3. Discuss tips to prevent common health issues
4. Explain the meaning of hygiene
5. Understand the purpose of Swacch Bharat Abhiyan
6. Explain the meaning of habit
7. Discuss ways to set up a safe work environment
8. Discuss critical safety habits to be followed by employees
9. Explain the importance of self-analysis
10. Understand motivation with the help of Maslow's Hierarchy of Needs
11. Discuss the meaning of achievement motivation
12. List the characteristics of entrepreneurs with achievement motivation
13. List the different factors that motivate you
14. Discuss how to maintain a positive attitude
15. Discuss the role of attitude in self-analysis
16. List your strengths and weaknesses
17. Discuss the qualities of honest people
18. Describe the importance of honesty in entrepreneurs
19. Discuss the elements of a strong work ethic
20. Discuss how to foster a good work ethic
21. List the characteristics of highly creative people
22. List the characteristics of highly innovative people
23. Discuss the benefits of time management
24. List the traits of effective time managers
25. Describe effective time management technique
26. Discuss the importance of anger management
27. Describe anger management strategies
28. Discuss tips for anger management
29. Discuss the causes of stress
30. Discuss the symptoms of stress
31. Discuss tips for stress management

5.1.1 Health, Habits, Hygiene: What is Health

As per the World Health Organization (WHO), health is a “State of complete physical, mental, and social well-being, and not merely the absence of disease or infirmity.” This means being healthy does not simply mean not being unhealthy – it also means you need to be at peace emotionally, and feel fit physically. For example, you cannot say you are healthy simply because you do not have any physical ailments like a cold or cough. You also need to think about whether you are feeling calm, relaxed and happy.

Common Health Issues

Some common health issues are:

- Allergies
- Asthma
- Skin Disorders
- Depression and Anxiety
- Diabetes
- Cough, Cold, Sore Throat
- Difficulty Sleeping
- Obesity

Tips to Prevent Health Issues

Taking measures to prevent ill health is always better than curing a disease or sickness. You can stay healthy by:

- Eating healthy foods like fruits, vegetables and nuts
- Cutting back on unhealthy and sugary foods
- Drinking enough water everyday
- Not smoking or drinking alcohol
- Exercising for at least 30 minutes a day, 4-5 times a week
- Taking vaccinations when required
- Practicing yoga exercises and meditation

How many of these health standards do you follow? Tick the ones that apply to you.

1. Get minimum 7-8 hours of sleep every night.
2. Avoid checking email first thing in the morning and right before you go to bed at night.
3. Don't skip meals – eat regular meals at correct meal times.
4. Read a little bit every single day.
5. Eat more home cooked food than junk food.

6. Stand more than you sit.
7. Drink a glass of water first thing in the morning and have at least 8 glasses of water through the day.
8. Go to the doctor and dentist for regular checkups.
9. Exercise for 30 minutes at least 5 days a week.
10. Avoid consuming lots of aerated beverages.

What is Hygiene?

As per the World Health Organization (WHO), “Hygiene refers to conditions and practices that help to maintain health and prevent the spread of diseases.” In other words, hygiene means ensuring that you do whatever is required to keep your surroundings clean, so that you reduce the chances of spreading germs and diseases.

For instance, think about the kitchen in your home. Good hygiene means ensuring that the kitchen is always spick and span, the food is put away, dishes are washed and dustbins are not overflowing with garbage. Doing all this will reduce the chances of attracting pests like rats or cockroaches, and prevent the growth of fungus and other bacteria, which could spread disease.

How many of these health standards do you follow? Tick the ones that apply to you.

1. Have a bath or shower every day with soap – and wash your hair with shampoo 2-3 times a week.
2. Wear a fresh pair of clean undergarments every day.
3. Brush your teeth in the morning and before going to bed.
4. Cut your fingernails and toenails regularly.
5. Wash your hands with soap after going to the toilet.
6. Use an anti-perspirant deodorant on your underarms if you sweat a lot.
7. Wash your hands with soap before cooking or eating.
8. Stay home when you are sick, so other people don't catch what you have.
9. Wash dirty clothes with laundry soap before wearing them again.
10. Cover your nose with a tissue/your hand when coughing or sneezing.

See how healthy and hygienic you are, by giving yourself 1 point for every ticked statement!

Then take a look at what your score means.

Your Score

0-7/20: You need to work a lot harder to stay fit and fine! Make it a point to practice good habits daily and see how much better you feel!

7-14/20: Not bad, but there is scope for improvement! Try and add a few more good habits to your daily routine.

14-20/20: Great job! Keep up the good work! Your body and mind thank you!

Swachh Bharat Abhiyan

We have already discussed the importance of following good hygiene and health practices for ourselves. But, it is not enough for us to be healthy and hygienic. We must also extend this standard to our homes, our immediate surroundings and to our country as a whole.

The 'Swachh Bharat Abhiyan' (Clean India Mission) launched by Prime Minister Shri Narendra Modi on 2nd October 2014, believes in doing exactly this. The aim of this mission is to clean the streets and roads of India and raise the overall level of cleanliness. Currently this mission covers 4,041 cities and towns across the country. Millions of our people have taken the pledge for a clean India. You should take the pledge too, and do everything possible to keep our country clean!

What are Habits?

A habit is a behaviour that is repeated frequently. All of us have good habits and bad habits. Keep in mind the phrase by John Dryden: "We first make our habits, and then our habits make us." This is why it is so important that you make good habits a way of life, and consciously avoid practicing bad habits.

Some good habits that you should make part of your daily routine are:

- Always having a positive attitude
- Making exercise a part of your daily routine
- Reading motivational and inspirational stories
- Smiling! Make it a habit to smile as often as possible
- Making time for family and friends
- Going to bed early and waking up early

Some bad habits that you should quit immediately are:

- Skipping breakfast
- Snacking frequently even when you are not hungry
- Eating too much fattening and sugary food
- Smoking, drinking alcohol and doing drugs
- Spending more money than you can afford
- Worrying about unimportant issues
- Staying up late and waking up late

Tips



- Following healthy and hygienic practices every day will make you feel good mentally and physically.
- Hygiene is two-thirds of health – so good hygiene will help you stay strong and healthy!

5.1.2: Safety: Tips to Design a Safe Workplace

Every employer is obligated to ensure that his workplace follows the highest possible safety protocol. When setting up a business, owners must make it a point to:

- Use ergonomically designed furniture and equipment to avoid stooping and twisting
- Provide mechanical aids to avoid lifting or carrying heavy objects
- Have protective equipment on hand for hazardous jobs
- Designate emergency exits and ensure they are easily accessible
- Set down health codes and ensure they are implemented
- Follow the practice of regular safety inspections in and around the workplace
- Ensure regular building inspections are conducted
- Get expert advice on workplace safety and follow it

Non-Negotiable Employee Safety Habits

Every employer is obligated to ensure that his workplace follows the highest possible safety protocol. When setting up a business, owners must make it a point to:

- Immediately report unsafe conditions to a supervisor
- Recognize and report safety hazards that could lead to slips, trips and falls
- Report all injuries and accidents to a supervisor
- Wear the correct protective equipment when required
- Learn how to correctly use equipment provided for safety purposes
- Be aware of and avoid actions that could endanger other people
- Take rest breaks during the day and some time off from work during the week

Tips

- Be aware of what emergency number to call at the time of a workplace emergency
- Practice evacuation drills regularly to avoid chaotic evacuations

5.1.3 Self Analysis – Attitude, Achievement Motivation: What is Self-Analysis

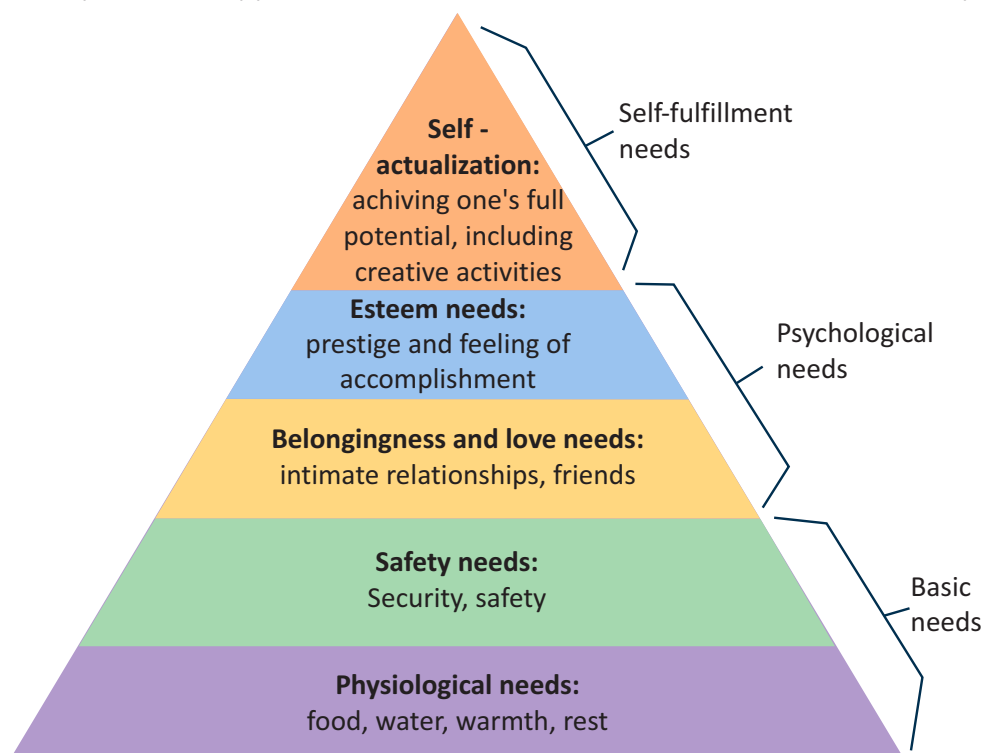
To truly achieve your full potential, you need to take a deep look inside yourself and find out what kind of person you really are. This attempt to understand your personality is known as self-analysis. Assessing yourself in this manner will help you grow, and will also help you to identify areas within yourself that need to be further developed, changed or eliminated. You can better understand yourself by taking a deep look at what motivates you, what your attitude is like, and what your strengths and weaknesses are.

What is Motivation?

Very simply put, motivation is your reason for acting or behaving in a certain manner. It is important to understand that not everyone is motivated by the same desires – people are motivated by many, many different things. We can understand this better by looking at Maslow's Hierarchy of Needs.

Maslow's Hierarchy of Needs

Famous American psychologist Abraham Maslow wanted to understand what motivates people. He believed that people have five types of needs, ranging from very basic needs (called physiological needs) to more important needs that are required for self-growth (called self-actualization needs). Between the physiological and self-actualization needs are three other needs – safety needs, belongingness and love needs, and esteem needs. These needs are usually shown as a pyramid with five levels and are known as Maslow's Hierarchy of Needs.



As you can see from the pyramid, the lowest level depicts the most basic needs. Maslow believed that our behaviour is motivated by our basic needs, until those needs are met. Once they are fulfilled, we move to the next level and are motivated by the next level of needs. Let's understand this better with an example.

Rupa comes from a very poor family. She never has enough food, water, warmth or rest. According to Maslow, until Rupa is sure that she will get these basic needs, she will not even think about the next level of needs – her safety needs. But, once Rupa is confident that her basic needs will be met, she will move to the next level, and her behaviour will then be motivated by her need for security and safety. Once these new needs are met, Rupa will once again move to the next level, and be motivated by her need for relationships and friends. Once this need is satisfied, Rupa will then focus on the fourth level of needs – her esteem needs, after which she will move up to the fifth and last level of needs – the desire to achieve her full potential.

Understanding Achievement Motivation

We now know that people are motivated by basic, psychological and self-fulfillment needs. However, certain people are also motivated by the achievement of highly challenging accomplishments. This is known as Achievement Motivation, or 'need for achievement'.

The level of motivation achievement in a person differs from individual to individual. It is important that entrepreneurs have a high level of achievement motivation – a deep desire to accomplish something important and unique. It is equally important that they hire people who are also highly motivated by challenges and success.

What Motivates You?

What are the things that really motivate you? List down five things that really motivate you. Remember to answer honestly!

I am motivated by:

Characteristics of Entrepreneurs with Achievement Motivation

Entrepreneurs with achievement motivation can be described as follows:

- Unafraid to take risks for personal accomplishment
- Love being challenged
- Future-oriented
- Flexible and adaptive
- Value negative feedback more than positive feedback
- Very persistent when it comes to achieving goals
- Extremely courageous
- Highly creative and innovative
- Restless - constantly looking to achieve more
- Feel personally responsible for solving problems

Think about it:

- How many of these traits do you have?
- Can you think of entrepreneurs who display these traits?

How to Cultivate a Positive Attitude

The good news is attitude is a choice. So it is possible to improve, control and change our attitude, if we decide we want to! The following tips help foster a positive mindset:

- Remember that you control your attitude, not the other way around
- Devote at least 15 minutes a day towards reading, watching or listening to something positive
- Avoid negative people who only complain and stop complaining yourself
- Expand your vocabulary with positive words and delete negative phrases from your mind
- Be appreciative and focus on what's good in yourself, in your life, and in others
- Stop thinking of yourself as a victim and start being proactive
- Imagine yourself succeeding and achieving your goals

What is Attitude?

Now that we understand why motivation is so important for self-analysis, let's look at the role our attitude plays in better understanding ourselves. Attitude can be described as your tendency (positive or negative), to think and feel about someone or something. Attitude is the foundation for success in every aspect of life. Our attitude can be our best friend or our worst enemy. In other words:

"The only disability in life is a bad attitude."

When you start a business, you are sure to encounter a wide variety of emotions, from difficult times and failures to good times and successes. Your attitude is what will see you through the tough times and guide you towards success. Attitude is also infectious. It affects everyone around you, from your customers to your employees to your investors. A positive attitude helps build confidence in the workplace while a negative attitude is likely to result in the demotivation of your people.

What Are Your Strengths and Weaknesses?

Another way to analyze yourself is by honestly identifying your strengths and weaknesses. This will help you use your strengths to your best advantage and reduce your weaknesses.

Note down all your strengths and weaknesses in the two columns below. Remember to be honest with yourself!

Strengths	Weaknesses

Tips



- Achievement motivation can be learned.
- Don't be afraid to make mistakes.
- Train yourself to finish what you start.
- Dream big.

5.1.4 Honesty & Work Ethics: What is Honesty?

Honesty is the quality of being fair and truthful. It means speaking and acting in a manner that inspires trust. A person who is described as honest is seen as truthful and sincere, and as someone who isn't deceitful or devious and doesn't steal or cheat. There are two dimensions of honesty – one is honesty in communication and the other is honesty in conduct.

Honesty is an extremely important trait because it results in peace of mind and builds relationships that are based on trust. Being dishonest, on the other hand, results in anxiety and leads to relationships full of distrust and conflict.

Qualities of Honest People

Honest individuals have certain distinct characteristics. Some common qualities among honest people are:

1. They don't worry about what others think of them. They believe in being themselves – they don't bother about whether they are liked or disliked for their personalities.
2. They stand up for their beliefs. They won't think twice about giving their honest opinion, even if they are aware that their point of view lies with the minority.
3. They are thick-skinned. This means they are not affected by others judging them harshly for their honest opinions.
4. They forge trusting, meaningful and healthy friendships. Honest people usually surround themselves with honest friends. They have faith that their friends will be truthful and upfront with them at all times.

They are trusted by their peers. They are seen as people who can be counted on for truthful and objective feedback and advice.

- **Honesty and employees:** When entrepreneurs build honest relationships with their employees, it leads to more transparency in the workplace, which results in higher work performance and better results.
- **Honesty and investors:** For entrepreneurs, being honest with investors means not only sharing strengths but also candidly disclosing current and potential weaknesses, problem areas and solution strategies. Keep in mind that investors have a lot of experience with startups and are aware that all new companies have problems. Claiming that everything is perfectly fine and running smoothly is a red flag for most investors.
- **Honesty with oneself:** The consequences of being dishonest with oneself can lead to dire results, especially in the case of entrepreneurs. For entrepreneurs to succeed, it is critical that they remain realistic about their situation at all times, and accurately judge every aspect of their enterprise for what it truly is.

Importance of Honesty in Entrepreneurs

One of the most important characteristics of entrepreneurs is honesty. When entrepreneurs are honest with their customers, employees and investors, it shows that they respect those that they work with. It is also important that entrepreneurs remain honest with themselves. Let's look at how being honest would lead to great benefits for entrepreneurs.

- **Honesty and customers:** When entrepreneurs are honest with their customers it leads to stronger relationships, which in turn results in business growth and a stronger customer network.

What are Work Ethics?

Being ethical in the workplace means displaying values like honesty, integrity and respect in all your decisions and communications. It means not displaying negative qualities like lying, cheating and stealing.

Workplace ethics play a big role in the profitability of a company. It is as crucial to an enterprise as high morale and teamwork. This is why most companies lay down specific workplace ethic guidelines that must compulsorily be followed by their employees. These guidelines are typically outlined in a company's employee handbook.

Elements of a Strong Work Ethic

An entrepreneur must display strong work ethics, as well as hire only those individuals who believe in and display the same level of ethical behavior in the workplace. Some elements of a strong work ethic are:

- **Professionalism:** This involves everything from how you present yourself in a corporate setting to the manner in which you treat others in the workplace.
- **Respectfulness:** This means remaining poised and diplomatic regardless of how stressful or volatile a situation is.
- **Dependability:** This means always keeping your word, whether it's arriving on time for a meeting or delivering work on time.
- **Dedication:** This means refusing to quit until the designated work is done, and completing the work at the highest possible level of excellence.
- **Determination:** This means embracing obstacles as challenges rather than letting them stop you, and pushing ahead with purpose and resilience to get the desired results.
- **Accountability:** This means taking responsibility for your actions and the consequences of your actions, and not making excuses for your mistakes.
- **Humility:** This means acknowledging everyone's efforts and hard work, and sharing the credit for accomplishments.

How to Foster a Good Work Ethic

As an entrepreneur, it is important that you clearly define the kind of behaviour that you expect from each and every team member in the workplace. You should make it clear that you expect employees to display positive work ethics like:

- **Honesty:** All work assigned to a person should be done with complete honesty, without any deceit or lies.
- **Good attitude:** All team members should be optimistic, energetic, and positive.
- **Reliability:** Employees should show up where they are supposed to be, when they are supposed to be there.
- **Good work habits:** Employees should always be well groomed, never use inappropriate language, conduct themselves professionally at all times, etc.
- **Initiative:** Doing the bare minimum is not enough. Every team member needs to be proactive and show initiative.
- **Trustworthiness:** Trust is non-negotiable. If an employee cannot be trusted, it's time to let that employee go.

- **Respect:** Employees need to respect the company, the law, their work, their colleagues and themselves.
- **Integrity:** Each and every team member should be completely ethical and must display above board behaviour at all times.
- **Efficiency:** Efficient employees help a company grow while inefficient employees result in a waste of time and resources.

Tips



- Don't get angry when someone tells you the truth and you don't like what you hear.
- Always be willing to accept responsibility for your mistakes.

5.1.5 Creativity & Innovation : What is Creativity

Creativity means thinking outside the box. It means viewing things in new ways or from different perspectives, and then converting these ideas into reality. Creativity involves two parts: thinking and producing. Simply having an idea makes you imaginative, not creative. However, having an idea and acting on it makes you creative.

Characteristics of Highly Creative People

Some characteristics of creative people are:

- They are imaginative and playful
- They see issues from different angles
- They notice small details
- They have very little tolerance for boredom
- They detest rules and routine
- They love to daydream
- They are very curious

What is Innovation?

There are many different definitions of innovation. In simple terms, innovation means turning an idea into a solution that adds value. It can also mean adding value by implementing a new product, service or process, or significantly improving on an existing product, service or process.

Characteristics of Highly Innovative People

Some characteristics of highly innovative people are:

- They embrace doing things differently
- They don't believe in taking shortcuts
- They are not afraid to be unconventional
- They are highly proactive and persistent
- They are organized, cautious and risk-averse

Tips



- Take regular breaks from your creative work to recharge yourself and gain fresh perspective.
- Build prototypes frequently, test them out, get feedback, and make the required changes.

5.1.6 Time Management: What is Time Management?

Time management is the process organizing your time, and deciding how to allocate your time between different activities. Good time management is the difference between working smart (getting more done in less time) and working hard (working for more time to get more done). Effective time management leads to an efficient work output, even when you are faced with tight deadlines and high pressure situations. On the other hand, not managing your time effectively results in inefficient output and increases stress and anxiety.

Benefits of Time Management

Time management can lead to huge benefits like:

- Greater productivity
- Better professional reputation
- Higher chances for career advancement
- Higher efficiency
- Reduced stress
- Greater opportunities to achieve goals

Not managing time effectively can result in undesirable consequences like:

- Missing deadlines
- Substandard work quality
- Stalled career
- Inefficient work output
- Poor professional reputation
- Increase in stress and anxiety

Traits of Effective Time Managers

Some traits of effective time managers are:

- They begin projects early
- They set daily objectives
- They modify plans if required, to achieve better results
- They are flexible and open-minded
- They inform people in advance if their help will be required
- They know how to say no
- They break tasks into steps with specific deadlines
- They continually review long term goals
- They think of alternate solutions if and when required
- They ask for help when required
- They create backup plans

Effective Time Management Techniques

You can manage your time better by putting into practice certain time management techniques. Some helpful tips are:

- Plan out your day as well as plan for interruptions. Give yourself at least 30 minutes to figure out your time plan. In your plan, schedule some time for interruptions.
- Put up a “Do Not Disturb” sign when you absolutely have to complete a certain amount of work.
- Close your mind to all distractions. Train yourself to ignore ringing phones, don’t reply to chat messages and disconnect from social media sites.

- Delegate your work. This will not only help your work get done faster, but will also show you the unique skills and abilities of those around you.
- Stop procrastinating. Remind yourself that procrastination typically arises due to the fear of failure or the belief that you cannot do things as perfectly as you wish to do them.
- Prioritize. List each task to be completed in order of its urgency or importance level. Then focus on completing each task, one by one.
- Maintain a log of your work activities. Analyze the log to help you understand how efficient you are, and how much time is wasted every day. Create time management goals to reduce time wastage.

Tips



- Always complete the most important tasks first.
- Get at least 7 – 8 hours of sleep every day.
- Start your day early.
- Don't waste too much time on small, unimportant details.
- Set a time limit for every task that you will undertake.
- Give yourself some time to unwind between tasks.

5.1.7 Anger Management: What is Anger Management

Anger management is the process of:

1. Learning to recognize the signs that you, or someone else, is becoming angry
2. Taking the best course of action to calm down the situation in a positive way

Anger management does not mean suppressing anger.

Importance of Anger Management

Anger is a perfectly normal human emotion. In fact, when managed the right way, anger can be considered a healthy emotion. However, if it is not kept in check, anger can make us act inappropriately and can lead to us saying or doing things that we will likely later regret.

Extreme anger can:

- **Hurt you physically:** It leads to heart disease, diabetes, a weakened immune system, insomnia, and high blood pressure.
- **Hurt you mentally:** It can cloud your thinking and lead to stress, depression and mental health issues.
- **Hurt your career:** It can result in alienating your colleagues, bosses, clients and lead to the loss of respect.
- **Hurt your relationships:** It makes it hard for your family and friends to trust you, be honest with you and feel comfortable around you.

This is why anger management, or managing anger appropriately, is so important.

Anger Management Strategies

Here are some strategies that can help you control your anger:

Strategy 1: Relaxation

Something as simple as breathing deeply and looking at relaxing images works wonders in calming down angry feelings. Try this simple breathing exercise:

1. Take a deep breath from your diaphragm (don't breathe from your chest)
2. Visualize your breath coming up from your stomach
3. Keep repeating a calming word like 'relax' or 'take it easy' (remember to keep breathing deeply while repeating the word)
4. Picture a relaxing moment (this can be from your memory or your imagination)

Follow this relaxation technique daily, especially when you realize that you're starting to feel angry.

Strategy 2: Cognitive Restructuring

Cognitive restructuring means changing the manner in which you think. Anger can make you curse, swear, exaggerate and act very dramatically. When this happens, force yourself to replace your angry thoughts with more logical ones. For instance, instead of thinking 'Everything is ruined' change your mindset and tell yourself 'It's not the end of the world and getting angry won't solve this'.

Strategy 3: Problem Solving

Getting angry about a problem that you cannot control is a perfectly natural response. Sometimes, try as you may, there may not be a solution to the difficulty you are faced with. In such cases, stop focusing on solving the problem, and instead focus on handling and facing the problem. Remind yourself that you will do your best to deal with the situation, but that you will not blame yourself if you don't get the solution you desire.

Strategy 4: Better Communication

When you're angry, it is very easy to jump to inaccurate conclusions. In this case, you need to force yourself to stop reacting, and think carefully about what you want to say, before saying it. Avoid saying the first thing that enters your head. Force yourself to listen carefully to what the other person is saying. Then think about the conversation before responding.

Strategy 5: Changing Your Environment

If you find that your environment is the cause of your anger, try and give yourself a break from your surroundings. Make an active decision to schedule some personal time for yourself, especially on days that are very hectic and stressful. Having even a brief amount of quiet or alone time is sure to help calm you down.

Tips for Anger Management

- The following tips will help you keep your anger in check:
- Take some time to collect your thoughts before you speak out in anger.
- Express the reason for your anger in an assertive, but non-confrontational manner once you have calmed down.
- Do some form of physical exercise like running or walking briskly when you feel yourself getting angry.
- Make short breaks part of your daily routine, especially during days that are stressful. Focus on how to solve a problem that's making you angry, rather than focusing on the fact that the problem is making you angry.

Tips

- Try to forgive those who anger you, rather than hold a grudge against them.
- Avoid using sarcasm and hurling insults. Instead, try and explain the reason for your frustration in a polite and mature manner.

5.1.8 Stress Management: What is Stress

We say we are 'stressed' when we feel overloaded and unsure of our ability to deal with the pressures placed on us. Anything that challenges or threatens our well-being can be defined as a stress. It is important to note that stress can be good and bad. While good stress keeps us going, negative stress undermines our mental and physical health. This is why it is so important to manage negative stress effectively.

Causes of Stress

Stress can be caused by internal and external factors.

Internal causes of stress

- Constant worry
- Rigid thinking
- Unrealistic expectations
- Pessimism
- Negative self-talk
- All in or all out attitude

External causes of stress

- Major life changes
- Difficulties with relationships
- Having too much to do
- Difficulties at work or in school
- Financial difficulties
- Worrying about one's children and/or family

Symptoms of Stress

Stress can manifest itself in numerous ways. Take a look at the cognitive, emotional, physical and behavioral symptoms of stress.

Cognitive Symptoms	Emotional Symptoms
<ul style="list-style-type: none"> • Memory problems • Concentration issues • Lack of judgement • Pessimism • Anxiety • Constant worrying 	<ul style="list-style-type: none"> • Depression • Agitation • Irritability • Loneliness • Anxiety • Anger

Physical Symptoms	Behavioral Symptoms
<ul style="list-style-type: none"> • Aches and pain • Diarrhea or constipation • Nausea • Dizziness • Chest pain and/or rapid heartbeat • Frequent cold or flu like feelings 	<ul style="list-style-type: none"> • Increase or decrease in appetite • Over sleeping or not sleeping enough • Withdrawing socially • Ignoring responsibilities • Consumption of alcohol or cigarettes • Nervous habits like nail biting, pacing etc.

Tips to Manage Stress

The following tips can help you manage your stress better:

- Note down the different ways in which you can handle the various sources of your stress.
- Remember that you cannot control everything, but you can control how you respond.
- Discuss your feelings, opinions and beliefs rather than reacting angrily, defensively or passively.
- Practice relaxation techniques like meditation, yoga or tai chi when you start feeling stressed.
- Devote a part of your day towards exercise.
- Eat healthy foods like fruits and vegetables. Avoid unhealthy foods especially those containing large amounts of sugar.
- Plan your day so that you can manage your time better, with less stress.
- Say no to people and things when required.
- Schedule time to pursue your hobbies and interests.
- Ensure you get at least 7-8 hours of sleep.
- Reduce your caffeine intake.
- Increase the time spent with family and friends.

Tips



- Force yourself to smile even if you feel stressed. Smiling makes us feel relaxed and happy.
- Stop yourself from feeling and thinking like a victim. Change your attitude and focus on being proactive.

UNIT 5.2: Digital Literacy: A Recap

Unit Objectives



By the end of this unit, participants will be able to:

1. Identify the basic parts of a computer
2. Identify the basic parts of a keyboard
3. Recall basic computer terminology
4. Recall basic computer terminology
5. Recall the functions of basic computer keys
6. Discuss the main applications of MS Office
7. Discuss the benefits of Microsoft Outlook
8. Discuss the different types of e-commerce
9. List the benefits of e-commerce for retailers and customers
10. Discuss how the Digital India campaign will help boost e-commerce in India
11. Describe how you will sell a product or service on an e-commerce platform

5.2.1 Computer and Internet basics: Basic Parts of a Computer

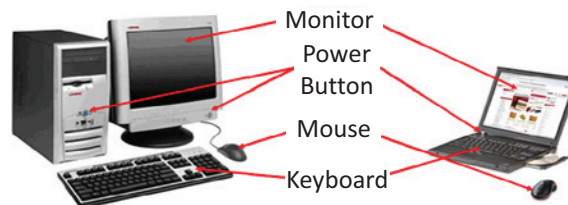


Fig 5.2.1 Basic parts of a computer

Basic Parts of a Keyboard

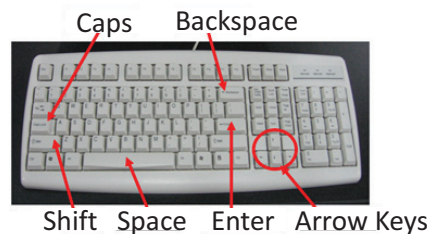


Fig 5.2.2 Basic parts of a Keyboard

Basic Parts of a Computer

- **Central Processing Unit (CPU):** The brain of the computer. It interprets and carries out program instructions.
- **Hard Drive:** A device that stores large amounts of data.
- **Monitor:** The device that contains the computer screen where the information is visually displayed.
- **Desktop:** The first screen displayed after the operating system loads.
- **Background:** The image that fills the background of the desktop.

Basic Parts of a Computer

- **Mouse:** A hand-held device used to point to items on the monitor.
- **Speakers:** Devices that enable you to hear sound from the computer.
- **Printer:** A device that converts output from a computer into printed paper documents.
- **Icon:** A small picture or image that visually represents something on your computer.
- **Cursor:** An arrow which indicates where you are positioned on the screen.
- **Program Menu:** A list of programs on your computer that can be accessed from the Start menu.
- **Taskbar:** The horizontal bar at the bottom of the computer screen that lists applications that are currently in use.
- **Recycle Bin:** A temporary storage for deleted files.

Basic Internet Terms

- **The Internet:** A vast, international collection of computer networks that transfers information.
- **The World Wide Web:** A system that lets you access information on the Internet.
- **Website:** A location on the World Wide Web (and Internet) that contains information about a specific topic.
- **Homepage:** Provides information about a website and directs you to other pages on that website.
- **Link/Hyperlink:** A highlighted or underlined icon, graphic, or text that takes you to another file or object.
- **Web Address/URL:** The address for a website.
- **Address Box:** A box in the browser window where you can type in a web address.

Basic Computer Keys

- **Arrow Keys:** Press these keys to move your cursor.
- **Space bar:** Adds a space.
- **Enter/Return:** Moves your cursor to a new line.
- **Shift:** Press this key if you want to type a capital letter or the upper symbol of a key.
- **Caps Lock:** Press this key if you want all the letters you type to be capital letters. Press it again to revert back to typing lowercase letters.
- **Backspace:** Deletes everything to the left of your cursor.

Tips



- When visiting a .com address, there no need to type http:// or even www. Just type the name of the website and then press Ctrl + Enter. (Example: Type 'apple' and press Ctrl + Enter to go to www.apple.com)
- Press the Ctrl key and press the + or - to increase and decrease the size of text.
- Press F5 or Ctrl + R to refresh or reload a web page.

5.2.2 MS Office and Email: About MS Office

MS Office or Microsoft Office is a suite of computer programs developed by Microsoft. Although meant for all users, it offers different versions that cater specifically to students, home users and business users. All the programs are compatible with both, Windows and Macintosh.

Most Popular Office Products

Some of the most popular and universally used MS Office applications are:

- **Microsoft Word:** Allows users to type text and add images to a document.
- **Microsoft Excel:** Allows users to enter data into a spreadsheet and create calculations and graphs.
- **Microsoft PowerPoint:** Allows users to add text, pictures and media and create slideshows and presentations.
- **Microsoft Outlook:** Allows users to send and receive email.
- **Microsoft OneNote:** Allows users to make drawings and notes with the feel of a pen on paper.
- **Microsoft Access:** Allows users to store data over many tables.

Why Choose Microsoft Outlook

A popular email management choice especially in the workplace, Microsoft Outlook also includes an address book, notebook, web browser and calendar. Some major benefits of this program are:

- **Integrated search function:** You can use keywords to search for data across all Outlook programs.
- **Enhanced security:** Your email is safe from hackers, junk mail and phishing website email.
- **Email syncing:** Sync your mail with your calendar, contact list, notes in One Note and...your phone!
- **Offline access to email:** No Internet? No problem! Write emails offline and send them when you're connected again.

Tips



- Press Ctrl+R as a shortcut method to reply to email.
- Set your desktop notifications only for very important emails.
- Flag messages quickly by selecting messages and hitting the Insert key.
- Save frequently sent emails as a template to reuse again and again.
- Conveniently save important emails as files.

5.2.3 E-Commerce: What is E-Commerce

E-commerce is the buying or selling of goods and services, or the transmitting of money or data, electronically on the internet. E-Commerce is the short form for “electronic commerce.”

Examples of E-Commerce

Some examples of e-commerce are:

- Online shopping
- Online auctions
- Online ticketing
- Electronic payments
- Internet banking

Types of E-Commerce

E-commerce can be classified based on the types of participants in the transaction. The main types of e-commerce are:

- **Business to Business (B2B):** Both the transacting parties are businesses.
- **Business to Consumer (B2C):** Businesses sell electronically to end-consumers.
- **Consumer to Consumer (C2C):** Consumers come together to buy, sell or trade items to other consumers.
- **Consumer-to-Business (C2B):** Consumers make products or services available for purchase to companies looking for exactly those services or products.
- **Business-to-Administration (B2A):** Online transactions conducted between companies and public administration.
- **Consumer-to-Administration (C2A):** Online transactions conducted between individuals and public administration.

Benefits of E-Commerce

The e-commerce business provides some benefits for retailers and customers.

Benefits for retailers:

- Establishes an online presence
- Reduces operational costs by removing overhead costs
- Increases brand awareness through the use of good keywords
- Increases sales by removing geographical and time constraints

Benefits for customers:

- Offers a wider range of choice than any physical store
- Enables goods and services to be purchased from remote locations
- Enables consumers to perform price comparisons

Digital India Campaign

Prime Minister Narendra Modi launched the Digital India campaign in 2015, with the objective of offering every citizen of India access to digital services, knowledge and information. The campaign aims to improve the country's online infrastructure and increase internet connectivity, thus boosting the e-commerce industry.

Currently, the majority of online transactions come from tier 2 and tier 3 cities. Once the Digital India campaign is in place, the government will deliver services through mobile connectivity, which will help deliver internet to remote corners of the country. This will help the e-commerce market to enter India's tier 4 towns and rural areas.

E-Commerce Activity

Choose a product or service that you want to sell online. Write a brief note explaining how you will use existing e-commerce platforms, or create a new e-commerce platform, to sell your product or service.

Tips



- Before launching your e-commerce platform, test everything.
- Pay close and personal attention to your social media.

UNIT 5.3: Money Matters

Unit Objectives



By the end of this unit, participants will be able to:

1. Discuss the importance of saving money
2. Discuss the benefits of saving money
3. Discuss the main types of bank accounts
4. Describe the process of opening a bank account
5. Differentiate between fixed and variable costs
6. Describe the main types of investment options
7. Describe the different types of insurance products
8. Describe the different types of taxes
9. Discuss the uses of online banking
10. Discuss the main types of electronic funds transfers

5.3.1 Personal Finance – Why to Save: Importance of Saving

We all know that the future is unpredictable. You never know what will happen tomorrow, next week or next year. That's why saving money steadily through the years is so important. Saving money will help improve your financial situation over time. But more importantly, knowing that you have money stashed away for an emergency will give you peace of mind. Saving money also opens the door to many more options and possibilities.

Benefits of Saving

Inculcating the habit of saving leads to a vast number of benefits. Saving helps you:

- **Become financially independent:** When you have enough money saved up to feel secure you can start making your choices, from taking a vacation whenever you want, to switching careers or starting your own business.
- **Invest in yourself through education:** Through saving, you can earn enough to pay up for courses that will add to your professional experience and ultimately result in higher paying jobs.
- **Get out of debt:** Once you have saved enough as a reserve fund, you can use your savings to pay off debts like loans or bills that have accumulated over time.
- **Be prepared for surprise expenses :** Having money saved enables you to pay for unforeseen expenses like sudden car or house repairs, without feeling financially stressed.
- **Pay for emergencies:** Saving helps you deal with emergencies like sudden health issues or emergency trips without feeling financially burdened.

- **Afford large purchases and achieve major goals:** Saving diligently makes it possible to place down payments towards major purchases and goals, like buying a home or a car.
- **Retire:** The money you have saved over the years will keep you comfortable when you no longer have the income you would get from your job.

Tips



- Break your spending habit. Try not spending on one expensive item per week, and put the money that you would have spent into your savings.
- Decide that you will not buy anything on certain days or weeks and stick to your word.

5.3.2 Types of Bank Accounts, Opening a Bank Account: Types of Bank Accounts

In India, banks offer four main types of bank accounts. These are:

- Current Accounts
- Savings Accounts
- Recurring Deposit Accounts
- Fixed Deposit Accounts

Current Accounts

Current accounts offer the most liquid deposits and thus, are best suited for businessmen and companies. As these accounts are not meant for investments and savings, there is no imposed limit on the number or amount of transactions that can be made on any given day. Current account holders are not paid any interest on the amounts held in their accounts. They are charged for certain services offered on such accounts.

Savings Accounts

Savings accounts are meant to promote savings, and are therefore the number one choice for salaried individuals, pensioners and students. While there is no restriction on the number and amount of deposits made, there are usually restrictions on the number and amount of withdrawals. Savings account holders are paid interest on their savings.

Recurring Deposit Accounts

Recurring Deposit accounts, also called RD accounts, are the accounts of choice for those who want to save an amount every month, but are unable to invest a large sum at one time. Such account holders deposit a small, fixed amount every month for a pre-determined period (minimum 6 months). Defaulting on a monthly payment results in the account holder being charged a penalty amount. The total amount is repaid with interest at the end of the specified period.

Fixed Deposit Accounts

Fixed Deposit accounts, also called FD accounts, are ideal for those who wish to deposit their savings for a long term in return for a high rate of interest. The rate of interest offered depends on the amount deposited and the time period, and also differs from bank to bank. In the case of an FD, a certain amount of money is deposited by the account holder for a fixed period of time. The money can be withdrawn when the period expires. If necessary, the depositor can break the fixed deposit prematurely. However, this usually attracts a penalty amount which also differs from bank to bank.

Opening a Bank Account

Opening a bank account is quite a simple process. Take a look at the steps to open an account of your own:

Step 1: Fill in the Account Opening Form

This form requires you to provide the following information:

- Personal details (name, address, phone number, date of birth, gender, occupation, address)
- Method of receiving your account statement (hard copy/email)
- Details of your initial deposit (cash/cheque)
- Manner of operating your account (online/mobile banking/traditional via cheque, slip books)

Ensure that you sign wherever required on the form.

Step 2: Affix your Photograph

Stick a recent photograph of yourself in the allotted space on the form.

Step 3: Provide your Know Your Customer (KYC) Details

KYC is a process that helps banks verify the identity and address of their customers. To open an account, every individual needs to submit certain approved documents with respect to photo identity (ID) and address proof. Some Officially Valid Documents (OVDs) are:

- Passport
- Driving License
- Voters' Identity Card
- PAN Card
- UIDAI (Aadhaar) Card

Step 4: Submit All your Documents

Submit the completed Account Opening Form and KYC documents. Then wait until the forms are processed and your account has been opened!

Tips

- Select the right type of account.
- Fill in complete nomination details.
- Ask about fees.
- Understand the rules.
- Check for online banking – it's convenient!
- Keep an eye on your bank balance.

5.3.3 Costs: Fixed vs Variable: What are Fixed and Variable Costs

Fixed costs and variable costs together make up a company's total cost. These are the two types of costs that companies have to bear when producing goods and services.

A fixed cost does not change with the volume of goods or services a company produces. It always remains the same.

A variable cost, on the other hand, increases and decreases depending on the volume of goods and services produced. In other words, it varies with the amount produced.

Differences Between Fixed and Variable Costs

Let's take a look at some of the main differences between fixed and variable costs:

Criteria	Fixed Costs	Variable Costs
Meaning	A cost that stays the same, regardless of the output produced.	A cost that changes when the
Nature	Time related.	Volume related.
Incurred	Incurred irrespective of units being produced.	Incurred only when units are produced.
Unit cost	Inversely proportional to the number of units produced.	Remains the same, per unit.
Examples	Depreciation, rent, salary, insurance, tax etc.	Material consumed, wages, commission on sales, packing expenses, etc.

Tips



- When trying to determine whether a cost is fixed or variable, simply ask the following question: Will the particular cost change if the company stopped its production activities? If the answer is no, then it is a fixed cost. If the answer is yes, then it is probably a variable cost.

5.3.4 Investment, Insurance and Taxes:

Investment

Investment means that money is spent today with the aim of reaping financial gains at a future time. The main types of investment options are as follows:

- **Bonds:** Bonds are instruments used by public and private companies to raise large sums of money – too large to be borrowed from a bank. These bonds are then issued in the public market and are bought by lenders.
- **Stocks:** Stocks or equity are shares that are issued by companies and are bought by the general public.
- **Small Savings Schemes:** Small Savings Schemes are tools meant to save money in small amounts. Some popular schemes are the Employees Provident Fund, Sukanya Samriddhi Scheme and National Pension Scheme.
- **Mutual Funds:** Mutual Funds are professionally managed financial instruments that invest money in different securities on behalf of investors.
- **Fixed Deposits:** A fixed amount of money is kept aside with a financial institution for a fixed amount of time in return for interest on the money.
- **Real Estate:** Loans are taken from banks to purchase real estate, which is then leased or sold with the aim of making a profit on the appreciated property price.
- **Hedge Funds:** Hedge funds invest in both financial derivatives and/or publicly traded securities.
- **Private Equity:** Private Equity is trading in the shares of an operating company that is not publicly listed and whose shares are not available on the stock market.
- **Venture Capital:** Venture Capital involves investing substantial capital in a budding company in return for stocks in that company.

Insurance

There are two types of insurance – Life Insurance and Non-Life or General Insurance.

Life Insurance

Life Insurance deals with all insurance covering human life.

Life Insurance Products

The main life insurance products are:

- **Term Insurance:** This is the simplest and cheapest form of insurance. It offers financial protection for a specified tenure, say 15 to 20 years. In the case of your death, your family is paid the sum assured. In the case of your surviving the term, the insurer pays nothing.
- **Endowment Policy:** This offers the dual benefit of insurance and investment. Part of the premium is allocated towards the sum assured, while the remaining premium gets invested in equity and debt. It pays a lump sum amount after the specified duration or on the death of the policyholder, whichever is earlier.
- **Unit-Linked Insurance Plan (ULIP):** Here part of the premium is spent on the life cover, while the remaining amount is invested in equity and debt. It helps develop a regular saving habit.

- **Money Back Life Insurance:** While the policyholder is alive, periodic payments of the partial survival benefits are made during the policy tenure. On the death of the insured, the insurance company pays the full sum assured along with survival benefits.
- **Whole Life Insurance:** It offers the dual benefit of insurance and investment. It offers insurance cover for the whole life of the person or up to 100 years whichever is earlier.

General Insurance

General Insurance deals with all insurance covering assets like animals, agricultural crops, goods, factories, cars and so on.

General Insurance Products

The main general insurance products are:

- **Motor Insurance:** This can be divided into Four Wheeler Insurance and Two Wheeler Insurance.
- **Health Insurance:** The main types of health insurance are individual health insurance, family floater health insurance, comprehensive health insurance and critical illness insurance.
- **Travel Insurance:** This can be categorised into Individual Travel Policy, Family Travel Policy, Student Travel Insurance and Senior Citizen Health Insurance.
- **Home Insurance:** This protects the house and its contents from risk.
- **Marine Insurance:** This insurance covers goods, freight, cargo etc. against loss or damage during transit by rail, road, sea and/or air.

Taxes

There are two types of taxes – Direct Taxes and Indirect Taxes.

Direct Tax

Direct taxes are levied directly on an entity or a person and are non-transferrable.

Some examples of Direct Taxes are:

- **Income Tax:** This tax is levied on your earning in a financial year. It is applicable to both, individuals and companies.
- **Capital Gains Tax:** This tax is payable whenever you receive a sizable amount of money. It is usually of two types – short term capital gains from investments held for less than 36 months and long term capital gains from investments held for longer than 36 months.
- **Securities Transaction Tax:** This tax is added to the price of a share. It is levied every time you buy or sell shares.
- **Perquisite Tax:** This tax is levied on perks that have been acquired by a company or used by an employee.
- **Corporate Tax:** Corporate tax is paid by companies from the revenue they earn.

Indirect Tax

Indirect taxes are levied on goods or services.

Some examples of Indirect Taxes are:

- **Sales Tax:** Sales Tax is levied on the sale of a product.

- **Service Tax:** Service Tax is added to services provided in India.
- **Value Added Tax:** Value Added Tax is levied at the discretion of the state government. The tax is levied on goods sold in the state. The tax amount is decided by the state.
- **Customs Duty & Octroi:** Customs Duty is a charge that is applied on purchases that are imported from another country. Octroi is levied on goods that cross state borders within India.
- **Excise Duty:** Excise Duty is levied on all goods manufactured or produced in India.

Tips



- Think about how quickly you need your money back and pick an investment option accordingly.
- Ensure that you are buying the right type of insurance policy for yourself.
- Remember, not paying taxes can result in penalties ranging from fines to imprisonment.

5.3.5 Online Banking, NEFT, RTGS etc.: What is Online Banking

Internet or online banking allows account holders to access their account from a laptop at any location. In this way, instructions can be issued. To access an account, account holders simply need to use their unique customer ID number and password.

Internet banking can be used to:

- Find out an account balance
- Transfer amounts from one account to another
- Arrange for the issuance of cheques
- Instruct payments to be made
- Request for a cheque book
- Request for a statement of accounts
- Make a fixed deposit

Electronic Funds Transfers

Electronic funds transfer is a convenient way of transferring money from the comfort of one's own home, using integrated banking tools like internet and mobile banking.

Transferring funds via an electronic gateway is extremely convenient. With the help of online banking, you can choose to:

- Transfer funds into your own accounts of the same bank.
- Transfer funds into different accounts of the same bank.
- Transfer funds into accounts in different banks, using NEFT.
- Transfer funds into other bank accounts using RTGS.
- Transfer funds into various accounts using IMPS.

NEFT

NEFT stands for National Electronic Funds Transfer. This money transfer system allows you to electronically transfer funds from your respective bank accounts to any other account, either in the same bank or belonging to any other bank. NEFT can be used by individuals, firms and corporate organizations to transfer funds between accounts.

In order to transfer funds via NEFT, two things are required:

- A transferring bank
- A destination bank

Before you can transfer funds through NEFT, you will need to register the beneficiary who will be receiving the funds. In order to complete this registration, you will require the following

- Recipient's name
- Recipient's account number
- Recipient's bank's name
- Recipient's bank's IFSC code

RTGS

RTGS stands for Real Time Gross Settlement. This is a real time funds transfer system which enables you to transfer funds from one bank to another, in real time or on a gross basis. The transferred amount is immediately deducted from the account of one bank, and instantly credited to the other bank's account. The RTGS payment gateway is maintained by the Reserve Bank of India. The transactions between banks are made electronically.

RTGS can be used by individuals, companies and firms to transfer large sums of money. Before remitting funds through RTGS, you will need to add the beneficiary and his bank account details via your online banking account. In order to complete this registration, you will require the following information:

- Name of the beneficiary
- Beneficiary's account number
- Beneficiary's bank address
- Beneficiary's bank's IFSC code

IMPS

IMPS stands for Immediate Payment Service. This is a real-time, inter-bank, electronic funds transfer system used to transfer money instantly within banks across India. IMPS enables users to make instant electronic transfer payments using mobile phones through both, Mobile Banking and SMS. It can also be used through ATMs and online banking. IMPS is available 24 hours a day and 7 days a week. The system features a secure transfer gateway and immediately confirms orders that have been fulfilled.

To transfer money through IMPS, the you need to:

- Register for IMPS with your bank
- Receive a Mobile Money Identifier (MMID) from the bank
- Receive a MPIN from the bank

Once you have both these, you can login or make a request through SMS to transfer a particular amount to a beneficiary.

For the beneficiary to receive the transferred money, he must:

1. Link his mobile number with his respective account
2. Receive the MMID from the bank

In order to initiate a money transfer through IMPS, you will need to enter the following information:

1. The beneficiary's mobile number
2. The beneficiary's MMID
3. The transfer amount
4. Your MPIN

As soon as money has been deducted from your account and credited into the beneficiary's account, you will be sent a confirmation SMS with a transaction reference number, for future reference.

Differences Between NEFT, RTGS & IMPS

Criteria	NEFT	RTGS	IMPS
Settlement	Done in batches	Real-time	Real-time
Full form	National Electronic Fund Transfer	Real Time Gross Settlement	Immediate Payment Service
Timings on Monday – Friday	8:00 am – 6:30 pm	9:00 am – 4:30 pm	24x7
Timings on Saturday	8:00 am – 1:00 pm	9:00 am – 1:30 pm	24x7
Minimum amount of money transfer limit	₹ 1	₹ 2 lacs	₹ 1
Maximum amount of money transfer limit	₹ 10 lacs	₹ 10 lacs per day	₹ 2 lacs
Maximum charges as per RBI	Upto 10,000 – ₹ 2.5 above 10,000 – 1 lac – ₹ 5 above 1 – 2 lacs – ₹ 15 above 2 – 5 lacs – ₹ 25 above 5 – 10 lacs – ₹ 25	above 2 – 5 lacs – ₹ 25 above 5 – 10 lacs – ₹ 50	Upto 10,000 – ₹ 5 above 10,000 – 1 lac – ₹ 5 above 1 – 2 lacs – ₹ 15

Tips



- Never click on any links in any e-mail message to access your online banking website.
- You will never be asked for your credit or debit card details while using online banking.
- Change your online banking password regularly.

UNIT 5.4: Preparing for Employment & Self Employment

Unit Objectives

By the end of this unit, participants will be able to:

1. Discuss the steps to prepare for an interview
2. Discuss the steps to create an effective Resume
3. Discuss the most frequently asked interview questions
4. Discuss how to answer the most frequently asked interview questions
5. Discuss basic workplace terminology

5.4.1 Interview Preparation: How to Prepare for an Interview

The success of your getting the job that you want depends largely on how well your interview for that job goes. Therefore, before you go in for your interview, it is important that you prepare for it with a fair amount of research and planning. Take a look at the steps to follow in order to be well prepared for an interview:

1. **Research the organization that you are having the interview with.**
 - Studying the company beforehand will help you be more prepared at the time of the interview. Your knowledge of the organization will help you answer questions at the time of the interview, and will leave you looking and feeling more confident. This is sure to make you stand out from other, not as well informed, candidates.
 - Look for background information on the company. Try and find an overview of the company and its industry profile.
 - Visit the company website to get a good idea of what the company does. A company website offers a wealth of important information. Read and understand the company's mission statement. Pay attention to the company's products/services and client list. Read through any press releases to get an idea of the company's projected growth and stability.
 - Note down any questions that you have after your research has been completed.
2. **Think about whether your skills and qualifications match the job requirements.**
 - Carefully read through and analyze the job description.
 - Make a note of the knowledge, skills and abilities required to fulfill the job requirements.
 - Take a look at the organization hierarchy. Figure out where the position you are applying for fits into this hierarchy.
3. **Go through the most typical interview questions asked, and prepare your responses.**
 - Remember, in most interviews a mix of resume-based, behavioral and case study questions are asked.
 - Think about the kind of answers you would like to provide to typical questions asked in these three areas.
 - Practice these answers until you can express them confidently and clearly.

4. Plan your attire for the interview.

- It is always safest to opt for formal business attire, unless expressly informed to dress in business casual (in which case you should use your best judgement).
- Ensure that your clothes are clean and well-ironed. Pick neutral colours – nothing too bright or flashy.
- The shoes you wear should match your clothes, and should be clean and suitable for an interview.
- Remember, your aim is to leave everyone you meet with the impression that you are a professional and highly efficient person.

5. Ensure that you have packed everything that you may require during the interview.

- Carry a few copies of your resume. Use a good quality paper for your resume print outs.
- Always take along a notepad and a pen.
- Take along any information you may need to refer to, in order to fill out an application form.
- Carry a few samples of your work, if relevant.

6. Remember the importance of non-verbal communication.

- Practice projecting confidence. Remind yourself to smile and make eye contact. Practice giving a firm handshake.
- Keep in mind the importance of posture. Practice sitting up straight. Train yourself to stop nervous gestures like fidgeting and foot-tapping.
- Practice keeping your reactions in check. Remember, your facial expressions provide a good insight into your true feelings. Practice projecting a positive image.

7. Make a list of questions to end the interview with.

- Most interviews will end with the interviewer(s) asking if you have any questions. This is your chance to show that you have done your research and are interested in learning more about the company.
- If the interviewer does not ask you this question, you can inform him/her that you have some queries that you would like to discuss. This is the time for you to refer to the notes you made while studying the company.
- Some good questions to ask at this point are:
 - What do you consider the most important criteria for success in this job?
 - How will my performance be evaluated?
 - What are the opportunities for advancement?
 - What are the next steps in the hiring process?
- Remember, never ask for information that is easily available on the company website.

Tips



- Ask insightful and probing questions.
- When communicating, use effective forms of body language like smiling, making eye contact, and actively listening and nodding. Don't slouch, play with nearby items, fidget, chew gum, or mumble.

5.4.2 Preparing an Effective Resume: How to Create an Effective Resume

A resume is a formal document that lists a candidate's work experience, education and skills. A good resume gives a potential employer enough information to believe the applicant is worth interviewing. That's why it is so important to create a résumé that is effective. Take a look at the steps to create an effective resume:

Step 1: Write the Address Section

The Address section occupies the top of your resume. It includes information like your name, address, phone number and e-mail address. Insert a bold line under the section to separate it from rest of your resume.

Example:

Jasmine Watts
Breach Candy, Mumbai – India
Contact No: +91 2223678270
Email: jasmine.watts@gmail.com

Step 2: Add the Profile Summary Section

This part of your resume should list your overall experiences, achievements, awards, certifications and strengths. You can make your summary as short as 2-3 bullet points or as long as 8-10 bullet points.

Example:

Profile Summary

- A Content Writer graduated from University of Strathclyde having 6 years of experience in writing website copy.
- Core expertise lies in content creation for e-learning courses, specifically for the K-12 segment.

Step 3: Include Your Educational Qualifications

When listing your academic records, first list your highest degree. Then add the second highest qualification under the highest one and so on. To provide a clear and accurate picture of your educational background, it is critical that include information on your position, rank, percentage or CPI for every degree or certification that you have listed.

If you have done any certifications and trainings, you can add a Trainings & Certifications section under your Educational Qualifications section.

Example:

Educational Qualifications

- Masters in International Management (2007) from Columbia University with 8.8 CPI.
- Bachelor of Management Studies (2004) from Mumbai University with 87% marks.
- 10+2 with Math, Stats (2001) from Maharashtra Board with 91% marks.
- High School (1999) from Maharashtra Board with 93% marks.

Step 4: List Your Technical Skills

When listing your technical skills, start with the skills that you are most confident about. Then add the skills that you do not have as good a command over. It is perfectly acceptable to include just one skill, if you feel that particular skill adds tremendous value to your résumé. If you do not have any technical skills, you can omit this step.

Example:**Technical Skills**

- Flash
- Photoshop

Step 5: Insert Your Academic Project Experience

List down all the important projects that you have worked on. Include the following information in this section:

- Project title
- Organization
- Platform used
- Contribution
- Description

Example:**Academic Projects**

Project Title: Different Communication Skills

Organization: True Blue Solutions

Platform used: Articulate

Contribution: Content writing and graphic visualization

Description: Development of storyboards for corporate induction & training programs

Step 6: List Your Strengths

This is where you list all your major strengths. This section should be in the form of a bulleted list.

Example:**Strengths**

- Excellent oral, written and presentation skills
- Action-oriented and result-focused
- Great time management skills

Step 7: List Your Extracurricular Activities

It is very important to show that you have diverse interests and that your life consists of more than academics. Including your extracurricular activities can give you an added edge over other candidates who have similar academic scores and project experiences. This section should be in the form of a bulleted list.

Example:**Extracurricular Activities**

- Member of the Debate Club
- Played tennis at a national level
- Won first prize in the All India Camel Contest, 2010

Step 8: Write Your Personal Details

The last section of your résumé must include the following personal information:

- Date of birth
- Gender & marital status
- Nationality
- Languages known

Example:**Personal Details**

- Date of birth: 25th May, 1981
- Gender & marital status: Female, Single
- Nationality: Indian
- Languages known: English, Hindi, Tamil, French

Tips

- Keep your resume file name short, simple and informational.
- Make sure the resume is neat and free from typing errors.
- Always create your resume on plain white paper.

5.4.3 Interview FAQs

Take a look at some of the most frequently asked interview questions, and some helpful tips on how to answer them.

Q1. Can you tell me a little about yourself?

Tips to answer:

- Don't provide your full employment or personal history.
- Offer 2-3 specific experiences that you feel are most valuable and relevant.
- Conclude with how those experiences have made you perfect for this specific role.

Q2. How did you hear about the position?

Tips to answer:

- Tell the interviewer how you heard about the job – whether it was through a friend (name the friend), event or article (name them) or a job portal (say which one).
- Explain what excites you about the position and what in particular caught your eye about this role.

Q3. What do you know about the company?

Tips to answer:

- Don't recite the company's About Us page.
- Show that you understand and care about the company's goals.
- Explain why you believe in the company's mission and values.

Q4. Why do you want this job?

Tips to answer:

- Show that you are passionate about the job.
- Identify why the role is a great fit for you.
- Explain why you love the company.

Q5. Why should we hire you?

Tips to answer:

- Prove through your words that you can not only do the work, but can definitely deliver excellent results.
- Explain why you would be a great fit with the team and work culture.
- Explain why you should be chosen over any other candidate.

Q6. What are your greatest professional strengths?

Tips to answer:

- Be honest – share some of your real strengths, rather than give answers that you think sound good.
- Offer examples of specific strengths that are relevant to the position you are applying for.
- Provide examples of how you've demonstrated these strengths.

Q7. What do you consider to be your weaknesses?

Tips to answer:

- The purpose of this question is to gauge your self-awareness and honesty.
- Give an example of a trait that you struggle with, but that you're working on to improve.

Q8. What are your salary requirements?**Tips to answer:**

- Do your research beforehand and find out the typical salary range for the job you are applying for.
- Figure out where you lie on the pay scale based on your experience, education, and skills.
- Be flexible. Tell the interviewer that you know your skills are valuable, but that you want the job and are willing to negotiate.

Q9. What do you like to do outside of work?**Tips to answer:**

- The purpose of this question is to see if you will fit in with the company culture.
- Be honest – open up and share activities and hobbies that interest and excite you.

Q10. If you were an animal, which one would you want to be?**Tips to answer:**

- The purpose of this question is to see if you are able to think on your feet.
- There's no wrong answer – but to make a great impression try to bring out your strengths or personality traits through your answer.

Q11: What do you think we could do better or differently?**Tips to answer:**

- The purpose of this question is to see if you have done your research on the company, and to test whether you can think critically and come up with new ideas.
- Suggest new ideas. Show how your interests and expertise would help you execute these ideas.

Q12: Do you have any questions for us?**Tips to answer:**

- Do not ask questions to which the answers can be easily found on the company website or through a quick online search.
- Ask intelligent questions that show your ability to think critically.

Tips

- Be honest and confident while answering.
- Use examples of your past experiences wherever possible to make your answers more impactful.

5.4.4 Work Readiness – Terms & Terminologies:

Basic Workplace Terminology

Every employee should be well versed in the following terms:

- **Annual leave:** Paid vacation leave given by employers to employees.
- **Background Check:** A method used by employers to verify the accuracy of the information provided by potential candidates.
- **Benefits:** A part of an employee's compensation package.
- **Breaks:** Short periods of rest taken by employees during working hours.
- **Compensation Package:** The combination of salary and benefits that an employer provides to his/her employees.
- **Compensatory Time (Comp Time):** Time off in lieu of pay.
- **Contract Employee:** An employee who works for one organization that sells said employee's services to another company, either on a project or time basis.
- **Contract of Employment:** When an employee is offered work in exchange for wages or salary, and accepts the offer made by the employer, a contract of employment exists.
- **Corporate Culture:** The beliefs and values shared by all the members of a company, and imparted from one generation of employees to another.
- **Counter Offer/Counter Proposal:** A negotiation technique used by potential candidates to increase the amount of salary offered by a company.
- **Cover Letter:** A letter that accompanies a candidate's resume. It emphasizes the important points in the candidate's resume and provides real examples that prove the candidate's ability to perform the expected job role.
- **Curriculum Vitae (CV)/Resume:** A summary of a candidate's achievements, educational background, work experience, skills and strengths.
- **Declining Letter:** A letter sent by an employee to an employer, turning down the job offer made by the employer to the employee.
- **Deductions:** Amounts subtracted from an employee's pay and listed on the employee's pay slip.
- **Discrimination:** The act of treating one person not as favourably as another person.
- **Employee:** A person who works for another person in exchange for payment.
- **Employee Training:** A workshop or in-house training that an employee is asked to attend by his or her superior, for the benefit of the employer.
- **Employment Gaps:** Periods of unemployed time between jobs.
- **Fixed-Term Contract:** A contract of employment which gets terminated on an agreed-upon date.
- **Follow-Up:** The act of contacting a potential employer after a candidate has submitted his or her resume.
- **Freelancer/Consultant/Independent Contractor:** A person who works for him or herself and pitches for temporary jobs and projects with different employers.
- **Holiday:** Paid time-off from work.
- **Hourly Rate:** The amount of salary or wages paid for 60 minutes of work.

- **Internship:** A job opportunity offered by an employer to a potential employee, called an intern, to work at the employer's company for a fixed, limited time period.
- **Interview:** A conversation between a potential employee and a representative of an employer, in order to determine if the potential employee should be hired.
- **Job Application:** A form which asks for a candidate's information like the candidate's name, address, contact details and work experience. The purpose of a candidate submitting a job application, is to show that candidate's interest in working for a particular company.
- **Job Offer:** An offer of employment made by an employer to a potential employee.
- **Job Search Agent:** A program that enables candidates to search for employment opportunities by selecting criteria listed in the program, for job vacancies.
- **Lay Off:** A lay off occurs when an employee is temporarily let go from his or her job, due to the employer not having any work for that employee.
- **Leave:** Formal permission given to an employee, by his or her employer, to take a leave of absence from work.
- **Letter of Acceptance:** A letter given by an employer to an employee, confirming the offer of employment made by the employer, as well as the conditions of the offer.
- **Letter of Agreement:** A letter that outlines the terms of employment.
- **Letter of Recommendation:** A letter written for the purpose of validating the work skills of a person.
- **Maternity Leave:** Leave taken from work by women who are pregnant, or who have just given birth.
- **Mentor:** A person who is employed at a higher level than you, who offers you advice and guides you in your career.
- **Minimum wage:** The minimum wage amount paid on an hourly basis.
- **Notice:** An announcement made by an employee or an employer, stating that the employment contract will end on a particular date.
- **Offer of Employment:** An offer made by an employer to a prospective employee that contains important information pertaining to the job being offered, like the starting date, salary, working conditions etc.
- **Open-Ended Contract:** A contract of employment that continues till the employer or employee terminates it.
- **Overqualified:** A person who is not suited for a particular job because he or she has too many years of work experience, or a level of education that is much higher than required for the job, or is currently or was previously too highly paid.
- **Part-Time Worker:** An employee who works for fewer hours than the standard number of hours normally worked.
- **Paternity Leave:** Leave granted to a man who has recently become a father.
- **Recruiters/Headhunters/Executive Search Firms:** Professionals who are paid by employers to search for people to fill particular positions.
- **Resigning/Resignations:** When an employee formally informs his or her employer that he or she is quitting his or her job.
- **Self-Employed:** A person who has his or her own business and does not work in the capacity of an employee.
- **Time Sheet:** A form that is submitted to an employer, by an employee, that contains the number of hours worked every day by the employee.

UNIT 5.5: Understanding Entrepreneurship

Unit Objectives



1. By the end of this unit, participants will be able to:
2. Discuss the concept of entrepreneurship
3. Discuss the importance of entrepreneurship
4. Describe the characteristics of an entrepreneur
5. Describe the different types of enterprises
6. List the qualities of an effective leader
7. Discuss the benefits of effective leadership
8. List the traits of an effective team
9. Discuss the importance of listening effectively
10. Discuss how to listen effectively
11. Discuss the importance of speaking effectively
12. Discuss how to speak effectively
13. Discuss how to solve problems
14. List important problem solving traits
15. Discuss ways to assess problem solving skills
16. Discuss the importance of negotiation
17. Discuss how to negotiate
18. Discuss how to identify new business opportunities
19. Discuss how to identify business opportunities within your business
20. Understand the meaning of entrepreneur
21. Describe the different types of entrepreneurs
22. List the characteristics of entrepreneurs
23. Recall entrepreneur success stories
24. Discuss the entrepreneurial process
25. Describe the entrepreneurship ecosystem
26. Discuss the government's role in the entrepreneurship ecosystem
27. Discuss the current entrepreneurship ecosystem in India
28. Understand the purpose of the Make in India campaign
29. Discuss the relationship between entrepreneurship and risk appetite
30. Discuss the relationship between entrepreneurship and resilience
31. Describe the characteristics of a resilient entrepreneur
32. Discuss how to deal with failure

5.5.1 Concept Introduction, (Characteristic of an Entrepreneur, types of firms / types of enterprises): Entrepreneurs and Entrepreneurship

Anyone who is determined to start a business, no matter what the risk, is an entrepreneur. Entrepreneurs run their own start-up, take responsibility for the financial risks and use creativity, innovation and vast reserves of self-motivation to achieve success. They dream big and are determined to do whatever it takes to turn their idea into a viable offering. The aim of an entrepreneur is to create an enterprise. The process of creating this enterprise is known as entrepreneurship.

Importance of Entrepreneurship

Entrepreneurship is very important for the following reasons:

1. It results in the creation of new organizations
2. It brings creativity into the marketplace
3. It leads to improved standards of living
4. It helps develop the economy of a country

Characteristics of Entrepreneurs

All successful entrepreneurs have certain characteristics in common.

They are all:

- Extremely passionate about their work
- Confident in themselves
- Disciplined and dedicated
- Motivated and driven
- Highly creative
- Visionaries
- Open-minded
- Decisive

Entrepreneurs also have a tendency to:

- Have a high risk tolerance
- Thoroughly plan everything
- Manage their money wisely
- Make their customers their priority
- Understand their offering and their market in detail
- Ask for advice from experts when required
- Know when to cut their losses

Examples of Famous Entrepreneurs

Some famous entrepreneurs are:

- Bill Gates (Founder of Microsoft)
- Steve Jobs (Co-founder of Apple)
- Mark Zuckerberg (Founder of Facebook)
- Pierre Omidyar (Founder of eBay)

Types of Enterprises

As an entrepreneur in India, you can own and run any of the following types of enterprises:

Sole Proprietorship

In a sole proprietorship, a single individual owns, manages and controls the enterprise. This type of business is the easiest to form with respect to legal formalities. The business and the owner have no separate legal existence. All profit belongs to the proprietor, as do all the losses - the liability of the entrepreneur is unlimited.

Partnership

A partnership firm is formed by two or more people. The owners of the enterprise are called partners. A partnership deed must be signed by all the partners. The firm and its partners have no separate legal existence. The profits are shared by the partners. With respect to losses, the liability of the partners is unlimited. A firm has a limited life span and must be dissolved when any one of the partners dies, retires, claims bankruptcy or goes insane.

Limited Liability Partnership (LLP)

In a Limited Liability Partnership or LLP, the partners of the firm enjoy perpetual existence as well as the advantage of limited liability. Each partner's liability is limited to their agreed contribution to the LLP. The partnership and its partners have a separate legal existence.

Tips



- Learn from others' failures.
- Be certain that this is what you want.
- Search for a problem to solve, rather than look for a problem to attach to your idea.

5.5.2 Leadership & Teamwork:

Leadership and Leaders

Leadership means setting an example for others to follow. Setting a good example means not asking someone to do something that you wouldn't willingly want to do yourself. Leadership is about figuring out what to do in order to win as a team, and as a company.

Leaders believe in doing the right things. They also believe in helping others to do the right things. An effective leader is someone who:

- Creates an inspiring vision of the future.
- Motivates and inspires his team to pursue that vision.

Leadership Qualities That All Entrepreneurs Need

Building a successful enterprise is only possible if the entrepreneur in charge possesses excellent leadership qualities. Some critical leadership skills that every entrepreneur must have are:

1. **Pragmatism:** This means having the ability to highlight all obstacles and challenges, in order to resolve issues and reduce risks.
2. **Humility:** This means admitting to mistakes often and early, and being quick to take responsibility for your actions. Mistakes should be viewed as challenges to overcome, not opportunities to point blame.
3. **Flexibility:** It is critical for a good leader to be very flexible and quickly adapt to change. It is equally critical to know when to adapt and when not to.
4. **Authenticity:** This means showing both, your strengths and your weaknesses. It means being human and showing others that you are human.
5. **Reinvention:** This means refreshing or changing your leadership style when necessary. To do this, it's important to learn where your leadership gaps lie and find out what resources are required to close them.
6. **Awareness:** This means taking the time to recognize how others view you. It means understanding how your presence affects those around you.

Benefits of Effective Leadership

Effective leadership results in numerous benefits. Great leadership leads to the leader successfully:

- Gaining the loyalty and commitment of the team members
- Motivating the team to work towards achieving the company's goals and objectives
- Building morale and instilling confidence in the team members
- Fostering mutual understanding and team-spirit among team members
- Convincing team members about the need to change when a situation requires adaptability

Teamwork and Teams

Teamwork occurs when the people in a workplace combine their individual skills to pursue a common goal. Effective teams are made up of individuals who work together to achieve this common goal. A great team is one who holds themselves accountable for the end result.

Importance of Teamwork in Entrepreneurial Success

For an entrepreneurial leader, building an effective team is critical to the success of a venture. An entrepreneur must ensure that the team he builds possesses certain crucial qualities, traits and characteristics. An effective team is one which has:

1. **Unity of purpose:** All the team members should clearly understand and be equally committed to the purpose, vision and goals of the team.
2. **Great communication skills:** Team members should have the ability to express their concerns, ask questions and use diagrams, and charts to convey complex information.
3. **The ability to collaborate:** Every member should feel entitled to provide regular feedback on new ideas.
4. **Initiative:** The team should consist of proactive individuals. The members should have the enthusiasm to come up with new ideas, improve existing ideas, and conduct their own research.
5. **Visionary members:** The team should have the ability to anticipate problems and act on these potential problem before they turn into real problems.
6. **Great adaptability skills:** The team must believe that change is a positive force. Change should be seen as the chance to improve and try new things.
12. **Excellent organizational skills:** The team should have the ability to develop standard work processes, balance responsibilities, properly plan projects, and set in place methods to measure progress and ROI.

Tips



- Don't get too attached to your original idea. Allow it to evolve and change.
- Be aware of your weaknesses and build a team that will complement your shortfalls.
- Hiring the right people is not enough. You need to promote or incentivize your most talented people to keep them motivated.
- Earn your team's respect.

5.5.3 Communication Skills: Listening & Speaking: The Importance of Listening Effectively

Listening is the ability to correctly receive and understand messages during the process of communication. Listening is critical for effective communication. Without effective listening skills, messages can easily be misunderstood. This results in a communication breakdown and can lead to the sender and the receiver of the message becoming frustrated or irritated.

It's very important to note that listening is not the same as hearing. Hearing just refers to sounds that you hear. Listening is a whole lot more than that. To listen, one requires focus. It means not only paying attention to the story, but also focusing on how the story is relayed, the way language and voice is used, and even how the speaker uses their body language. The ability to listen depends on how effectively one can perceive and understand both, verbal and non-verbal cues.

How to Listen Effectively

To listen effectively you should:

- Stop talking
- Stop interrupting
- Focus completely on what is being said
- Nod and use encouraging words and gestures
- Be open-minded
- Think about the speaker's perspective
- Be very, very patient
- Pay attention to the tone that is being used
- Pay attention to the speaker's gestures, facial expressions and eye movements
- Not try and rush the person
- Not let the speaker's mannerisms or habits irritate or distract you

How to Listen Effectively

How successfully a message gets conveyed depends entirely on how effectively you are able to get it through. An effective speaker is one who enunciates properly, pronounces words correctly, chooses the right words and speaks at a pace that is easily understandable. Besides this, the words spoken out loud need to match the gestures, tone and body language used.

What you say, and the tone in which you say it, results in numerous perceptions being formed. A person who speaks hesitantly may be perceived as having low self-esteem or lacking in knowledge of the discussed topic. Those with a quiet voice may very well be labelled as shy. And those who speak in commanding tones with high levels of clarity, are usually considered to be extremely confident. This makes speaking a very critical communication skill.

How to Speak Effectively

To speak effectively you should:

- Incorporate body language in your speech like eye contact, smiling, nodding, gesturing etc.
- Build a draft of your speech before actually making your speech.
- Ensure that all your emotions and feelings are under control.
- Pronounce your words distinctly with the correct pitch and intensity. Your speech should be crystal clear at all times.
- Use a pleasant and natural tone when speaking. Your audience should not feel like you are putting on an accent or being unnatural in any way.
- Use precise and specific words to drive your message home. Ambiguity should be avoided at all costs.
- Ensure that your speech has a logical flow.
- Be brief. Don't add any unnecessary information.
- Make a conscious effort to avoid irritating mannerisms like fidgeting, twitching etc.
- Choose your words carefully and use simple words that the majority of the audience will have no difficulty understanding.
- Use visual aids like slides or a whiteboard.
- Speak slowly so that your audience can easily understand what you're saying. However, be careful not to speak too slowly because this can come across as stiff, unprepared or even condescending.
- Remember to pause at the right moments.

Tips



- If you're finding it difficult to focus on what someone is saying, try repeating their words in your head.
- Always maintain eye contact with the person that you are communicating with, when speaking as well as listening. This conveys and also encourages interest in the conversation.

5.5.4 Problem Solving & Negotiation skills:

What is a Problem?

As per The Concise Oxford Dictionary (1995), a problem is, “A doubtful or difficult matter requiring a solution”

All problems contain two elements:

1. Goals
2. Obstacles

The aim of problem solving is to recognize the obstacles and remove them in order to achieve the goals.

How to Solve Problems

Solving a problem requires a level of rational thinking. Here are some logical steps to follow when faced with an issue:

Step 1: Identify the problem

Step 2: Study the problem in detail

Step 3: List all possible solutions

Step 4: Select the best solution

Step 5: Implement the chosen solution

Step 6: Check that the problem has really been solved

Important Traits for Problem Solving

Highly developed problem solving skills are critical for both, business owners and their employees. The following personality traits play a big role in how effectively problems are solved:

- Being open minded
- Being proactive
- Having a positive attitude
- Asking the right questions
- Not panicking
- Focusing on the right problem

How to Assess for Problem Solving Skills

As an entrepreneur, it would be a good idea to assess the level of problem solving skills of potential candidates before hiring them. Some ways to assess this skill are through:

1. **Application forms:** Ask for proof of the candidate’s problem solving skills in the application form.
2. **Psychometric tests:** Give potential candidates logical reasoning and critical thinking tests and see how they fare.
3. **Interviews:** Create hypothetical problematic situations or raise ethical questions and see how the candidates respond.
4. **Technical questions:** Give candidates examples of real life problems and evaluate their thought process.

What is Negotiation?

Negotiation is a method used to settle differences. The aim of negotiation is to resolve differences through a compromise or agreement while avoiding disputes. Without negotiation, conflicts are likely to lead to resentment between people. Good negotiation skills help satisfy both parties and go a long way towards developing strong relationships.

Why Negotiate

Starting a business requires many, many negotiations. Some negotiations are small while others are critical enough to make or break a startup. Negotiation also plays a big role inside the workplace. As an entrepreneur, you need to not only know how to negotiate yourself, but also how to train employees in the art of negotiation.

How to Negotiate

Take a look at some steps to help you negotiate:

Step 1: Pre-Negotiation Preparation	Agree on where to meet to discuss the problem, decide who all will be present and set a time limit for the discussion.
Step 2: Discuss the Problem	This involves asking questions, listening to the other side, putting your views forward and clarifying doubts.
Step 3: Clarify the Objective	Ensure that both parties want to solve the same problem and reach the same goal.
Step 4: Aim for a Win-Win Outcome	Try your best to be open minded when negotiating. Compromise and offer alternate solutions to reach an outcome where both parties win.
Step 5: Clearly Define the Agreement	When an agreement has been reached, the details of the agreement should be crystal clear to both sides, with no scope for misunderstandings.
Step 6: Implement the Agreed Upon Solution	Agree on a course of action to set the solution in motion

Tips

- Know exactly what you want before you work towards getting it
- Give more importance to listening and thinking, than speaking
- Focus on building a relationship rather than winning
- Remember that your people skills will affect the outcome
- Know when to walk away – sometimes reaching an agreement may not be possible

5.5.5 Business Opportunities Identification: Entrepreneurs and Opportunities

“The entrepreneur always searches for change, responds to it and exploits it as an opportunity.”

Peter Drucker

The ability to identify business opportunities is an essential characteristic of an entrepreneur.

What is an Opportunity?

The word opportunity suggests a good chance or a favourable situation to do something offered by circumstances.

A business opportunity means a good or favourable change available to run a specific business in a given environment, at a given point of time.

Common Questions Faced by Entrepreneurs

A critical question that all entrepreneurs face is how to go about finding the business opportunity that is right for them.

Some common questions that entrepreneurs constantly think about are:

- Should the new enterprise introduce a new product or service based on an unmet need?
- Should the new enterprise select an existing product or service from one market and offer it in another where it may not be available?
- Should the enterprise be based on a tried and tested formula that has worked elsewhere?

It is therefore extremely important that entrepreneurs must learn how to identify new and existing business opportunities and evaluate their chances of success.

When is an Idea an Opportunity?

An idea is an opportunity when:

- It creates or adds value to a customer
- It solves a significant problem, removes a pain point or meets a demand
- Has a robust market and profit margin
- Is a good fit with the founder and management team at the right time and place

Factors to Consider When Looking for Opportunities

Consider the following when looking for business opportunities:

- | | |
|--|--------------------------------|
| • Economic trends | • Market trends |
| • Changes in funding | • Changes in political support |
| • Changing relationships between vendors, partners and suppliers | • Shift in target audience |

Ways to Identify New Business Opportunities

1. Identify Market Inefficiencies

When looking at a market, consider what inefficiencies are present in the market. Think about ways to correct these inefficiencies.

2. Remove Key Hassles

Rather than create a new product or service, you can innovatively improve a product, service or process.

3. Create Something New

Think about how you can create a new experience for customers, based on existing business models.

4. Pick a Growing Sector/Industry

Research and find out which sectors or industries are growing and think about what opportunities you can tap in the same.

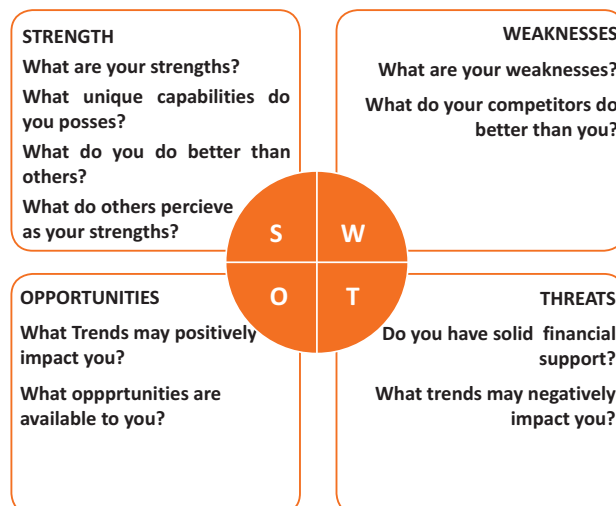
5. Think About Product Differentiation

If you already have a product in mind, think about ways to set it apart from the existing ones.

Ways to Identify Business Opportunities Within Your Business

1. SWOT Analysis

An excellent way to identify opportunities inside your business is by creating a SWOT analysis. The acronym SWOT stands for strengths, weaknesses, opportunities, and threats. SWOT analysis framework:



Consider the following when looking for business opportunities:

By looking at yourself and your competitors using the SWOT framework, you can uncover opportunities that you can exploit, as well as manage and eliminate threats that could derail your success.

2. Establishing Your USP

Establish your USP and position yourself as different from your competitors. Identify why customers should buy from you and promote that reason.

Opportunity Analysis

Once you have identified an opportunity, you need to analyze it.

To analyze an opportunity, you must:

- Focus on the idea
- Focus on the market of the idea
- Talk to industry leaders in the same space as the idea
- Talk to players in the same space as the idea

Tips



- Remember, opportunities are situational.
- Look for a proven track record.
- Avoid the latest craze.
- Love your idea.

5.5.6 Entrepreneurship Support Eco - System: What is an Entrepreneur?

An entrepreneur is a person who:

- Does not work for an employee
- Runs a small enterprise
- Assumes all the risks and rewards of the enterprise, idea, good or service

Types of Entrepreneurs

There are four main types of entrepreneurs:

1. **The Traditional Entrepreneur:** This type of entrepreneur usually has some kind of skill – they can be a carpenter, mechanic, cook etc. They have businesses that have been around for numerous years like restaurants, shops and carpenters. Typically, they gain plenty of experience in a particular industry before they begin their own business in a similar field.
2. **The Growth Potential Entrepreneur:** The desire of this type of entrepreneur is to start an enterprise that will grow, win many customers and make lots of money. Their ultimate aim is to eventually sell their enterprise for a nice profit. Such entrepreneurs usually have a science or technical background.
3. **The Project-Oriented Entrepreneur:** This type of entrepreneur generally has a background in the Arts or psychology. Their enterprises tend to be focus on something that they are very passionate about.
4. **The Lifestyle Entrepreneur:** This type of entrepreneur has usually worked as a teacher or a secretary. They are more interested in selling something that people will enjoy, rather than making lots of money.

Characteristics of an Entrepreneur

Successful entrepreneurs have the following characteristics:

- They are highly motivated
- They are creative and persuasive
- They are mentally prepared to handle each and every task
- They have excellent business skills – they know how to evaluate their cash flow, sales and revenue
- They are willing to take great risks
- They are very proactive – this means they are willing to do the work themselves, rather than wait for someone else to do it
- They have a vision – they are able to see the big picture
- They are flexible and open-minded
- They are good at making decisions

Entrepreneur Success Stories

Dhiru Bhai Ambani

Dhirubhai Ambani began his entrepreneurial career by selling “bhajias” to pilgrims in Mount Girnar on weekends. At 16, he moved to Yemen where he worked as a gas-station attendant, and as a clerk in an oil company. He returned to India with Rs. 50,000 and started a textile trading company. Reliance went on to become the first Indian company to raise money in global markets and the first Indian company to feature in Forbes 500 list.

Dr. Karsanbhai Patel

Karsanbhai Patel made detergent powder in the backyard of his house. He sold his product door-to-door and offered a money back guarantee with every pack that was sold. He charged Rs. 3 per kg when the cheapest detergent at that time was Rs.13 per kg. Dr. Patel eventually started Nirma which became a whole new segment in the Indian domestic detergent market.

The Entrepreneurial Process

Let’s take a look at the stages of the entrepreneurial process.

Stage 1: Idea Generation. The entrepreneurial process begins with an idea that has been thought of by the entrepreneur. The idea is a problem that has the potential to be solved.

Stage 2: Germination or Recognition. In this stage a possible solution to the identified problem is thought of.

Stage 3: Preparation or Rationalization. The problem is studied further and research is done to find out how others have tried to solve the same problem.

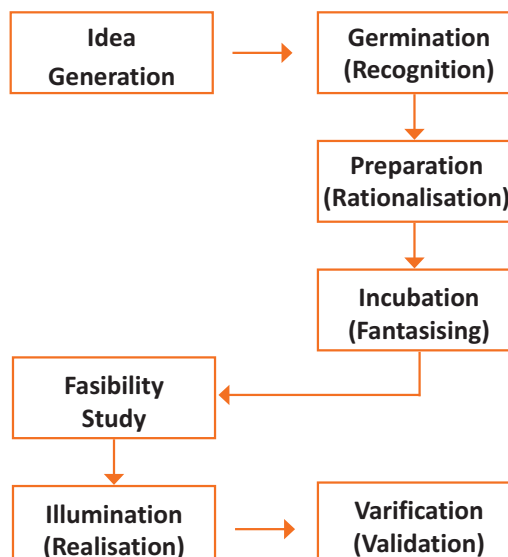
Stage 4: Incubation or Fantasizing. This stage involves creative thinking for the purpose of coming up with more ideas. Less thought is given to the problem areas.

Stage 5: Feasibility Study: The next step is the creation of a feasibility study to determine if the idea will make a profit and if it should be seen through.

Stage 6: Illumination or Realization. This is when all uncertain areas suddenly become clear. The entrepreneur feels confident that his idea has merit.

Stage 7: Verification or Validation. In this final stage, the idea is verified to see if it works and if it is useful.

Take a look at the diagram below to get a better idea of this process.



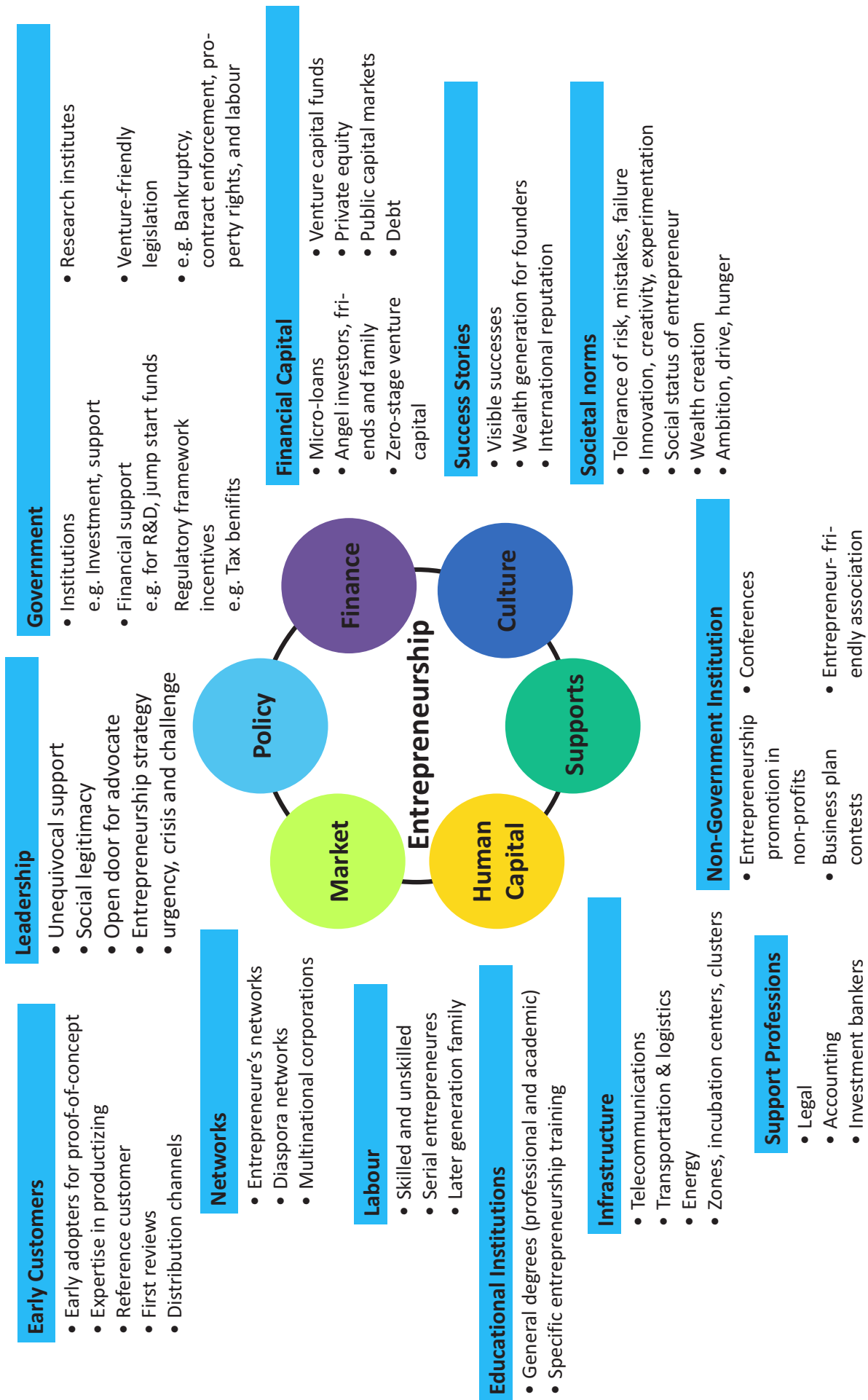
What is an Entrepreneur?

The entrepreneurship support ecosystem signifies the collective and complete nature of entrepreneurship. New companies emerge and flourish not only because of the courageous, visionary entrepreneurs who launch them, but they thrive as they are set in an environment or 'ecosystem' made of private and public participants. These players nurture and sustain the new ventures, facilitating the entrepreneurs' efforts.

An entrepreneurship ecosystem comprises of the following six domains:

1. **Favourable Culture:** This includes elements such as tolerance of risk and errors, valuable networking and positive social standing of the entrepreneur.
2. **Facilitating Policies & Leadership:** This includes regulatory framework incentives and existence of public research institutes.
3. **Financing Options:** Angel financing, venture capitalists and micro loans would be good examples of this.
4. **Human Capital:** This refers to trained and untrained labour, entrepreneurs and entrepreneurship training programmes, etc.
5. **Conducive Markets for Products & Services:** This refers to an existence or scope of existence of a market for the product/service.
6. **Institutional & Infrastructural Support:** This includes legal and financing advisers, telecommunications, digital and transportation infrastructure, and entrepreneurship networking programmes.

These domains indicate whether there is a strong entrepreneurship support ecosystem and what actions should the government put in place to further encourage this ecosystem. The six domains and their various elements have been graphically depicted.



Every entrepreneurship support ecosystem is unique and all the elements of the ecosystem are interdependent. Although every region's entrepreneurship ecosystem can be broadly described by the above features, each ecosystem is the result of the hundred elements interacting in highly complex and particular ways.

Entrepreneurship ecosystems eventually become (largely) self-sustaining. When the six domains are resilient enough, they are mutually beneficial. At this point, government involvement can and should be significantly minimized. Public leaders do not need to invest a lot to sustain the ecosystem. It is imperative that the entrepreneurship ecosystem incentives are formulated to be self-liquidating, hence focusing on sustainability of the environment.

Government's Role in the Entrepreneurship Ecosystem

Encouraging new ventures is a major focus for policymakers. Governments across the world are recognizing that new businesses flourish in distinctive types of supportive environments. Policymakers should study the scenario and take into account the following points whilst they formulate policies and regulations that enable successful entrepreneurship support ecosystems.

1. Policymakers should avoid regulations that discourage new entrants and work towards building efficient methods for business startups. Policies and regulations that favour existing, dominant firms over entrepreneurial ventures, restrict competition and obstruct entry for new companies.
2. Instead of developing policies conceptually intended to correct market failures, policymakers should interact with entrepreneurs and understand the challenges faced by them. The feedback should be used to develop policies that incite idea exploration, product development and increased rates of deal flow.
3. Entrepreneurial supporters should create a database that enables identifying who the participants in the ecosystem are and how they are connected. These ecosystem maps are useful tools in developing engagement strategies.
4. Disruptions are unavoidable in economic and social life. However, it's important to note that economic disruption gives rise to entrepreneurial opportunities. Architects of the entrepreneurship ecosystems (entrepreneurs, mentors, policymakers and consumers,) should anticipate these dips, thus capitalizing on the opportunities they create.

The need for effective strategies to enable local entrepreneurship support ecosystems is a practical one. Better understanding of the actual ecosystems provides a framework within which policy makers can ask relevant questions, envisage more efficient approaches, and assess ensuing outcomes.

Snapshot of the Entrepreneurship Ecosystem in India

Entrepreneurship has earned a newfound respect in India. Many Indians, with exposure to the world of business, who traditionally would have opted for a job, are setting up their own ventures. Many elements of the entrepreneurship ecosystem are beginning to come together. For example, increase in venture capitalists, government schemes and incubators, academia industry linkages, and emerging clusters and support to rural economy. All these initiatives are effective but there is a need to scale up and enrich the ecosystem further in the following ways:

1. We need to review our attitude towards failures and accept them as learning experiences.
2. We must encourage the educated to become entrepreneurs and provide students in schools and colleges with entrepreneurship skills.

3. Universities, research labs and the government need to play the role of enablers in the entrepreneurship support ecosystem.
4. Policymakers need to focus on reducing the obstacles such as corruption, red tape and bureaucracy.
5. We need to improve our legal systems and court international venture capital firms and bring them to India.
6. We must devise policies and methods to reach the secondary and tertiary towns in India, where people do not have access to the same resources available in the cities.

Today, there is a huge opportunity in this country to introduce innovative solutions that are capable of scaling up, and collaborating within the ecosystem as well as enriching it.

Make in India Campaign

Every entrepreneur has certain needs. Some of their important needs are:

- To easily get loans
- To easily find investors
- To get tax exemptions
- To easily access resources and good infrastructure
- To enjoy a procedure that is free of hassles and is quick
- To be able to easily partner with other firms

The Make in India campaign, launched by Prime Minister Modi aims to satisfy all these needs of young, aspiring entrepreneurs. Its objective is to:

- Make investment easy
- Support new ideas
- Enhance skill development
- Safeguard the ideas of entrepreneurs
- Create state-of-the-art facilities for manufacturing goods

Tips



- Research the existing market, network with other entrepreneurs, venture capitalists, angel investors, and thoroughly review the policies in place to enable your entrepreneurship.
- Failure is a stepping stone and not the end of the road. Review yours and your peers' errors and correct them in your future venture.
- Be proactive in your ecosystem. Identify the key features of your ecosystem and enrich them to ensure self-sustainability of your entrepreneurship support ecosystem.

5.5.7 Risk Appetite & Resilience: Entrepreneurship and Risk

Entrepreneurs are inherently risk takers. They are path-makers not path-takers. Unlike a normal, cautious person, an entrepreneur would not think twice about quitting his job (his sole income) and taking a risk on himself and his idea.

An entrepreneur is aware that while pursuing his dreams, assumptions can be proven wrong and unforeseen events may arise. He knows that after dealing with numerous problems, success is still not guaranteed. Entrepreneurship is synonymous with the ability to take risks. This ability, called risk-appetite, is an entrepreneurial trait that is partly genetic and partly acquired.

What is Risk Appetite?

Risk appetite is defined as the extent to which a company is equipped to take risk, in order to achieve its objectives. Essentially, it refers to the balance, struck by the company, between possible profits and the hazards caused by changes in the environment (economic ecosystem, policies, etc.). Taking on more risk may lead to higher rewards but have a high probability of losses as well. However, being too conservative may go against the company as it can miss out on good opportunities to grow and reach their objectives.

The levels of risk appetite can be broadly categorized as “low”, “medium” and “high.” The company’s entrepreneur(s) have to evaluate all potential alternatives and select the option most likely to succeed. Companies have varying levels of risk appetites for different objectives. The levels depend on:

- The type of industry
- Market pressures
- Company objectives

For example, a startup with a revolutionary concept will have a very high risk appetite. The startup can afford short term failures before it achieves longer term success. This type of appetite will not remain constant and will be adjusted to account for the present circumstances of the company.

Risk Appetite Statement

Companies have to define and articulate their risk appetite in sync with decisions made about their objectives and opportunities. The point of having a risk appetite statement is to have a framework that clearly states the acceptance and management of risk in business. It sets risk taking limits within the company. The risk appetite statement should convey the following:

- The nature of risks the business faces.
- Which risks the company is comfortable taking on and which risks are unacceptable.
- How much risk to accept in all the risk categories.
- The desired tradeoff between risk and reward.
- Measures of risk and methods of examining and regulating risk exposures.

Entrepreneurship and Resilience

Entrepreneurs are characterized by a set of qualities known as resilience. These qualities play an especially large role in the early stages of developing an enterprise. Risk resilience is an extremely valuable characteristic as it is believed to protect entrepreneurs against the threat of challenges and changes in the business environment.

What is Entrepreneurial Resilience?

Resilience is used to describe individuals who have the ability to overcome setbacks related to their life and career aspirations. A resilient person is someone who is capable of easily and quickly recovering from setbacks. For the entrepreneur, resilience is a critical trait. Entrepreneurial resilience can be enhanced in the following ways:

- By developing a professional network of coaches and mentors
- By accepting that change is a part of life
- By viewing obstacles as something that can be overcome

Characteristics of a Resilient Entrepreneur

The characteristics required to make an entrepreneur resilient enough to go the whole way in their business enterprise are:

- A strong internal sense of control
- Strong social connections
- Skill to learn from setbacks
- Ability to look at the bigger picture
- Ability to diversify and expand
- Survivor attitude
- Cash-flow conscious habits
- Attention to detail

Tips

- Cultivate a great network of clients, suppliers, peers, friends and family. This will not only help you promote your business, but will also help you learn, identify new opportunities and stay tuned to changes in the market.
- Don't dwell on setbacks. Focus on what you need to do next to get moving again.
- While you should try and curtail expenses, ensure that it is not at the cost of your growth.

5.5.8 Success & Failures: Understanding Successes and Failures in Entrepreneurship

Shyam is a famous entrepreneur, known for his success story. But what most people don't know, is that Shyam failed numerous times before his enterprise became a success. Read his interview to get an idea of what entrepreneurship is really about, straight from an entrepreneur who has both, failed and succeeded.

Interviewer: Shyam, I have heard that entrepreneurs are great risk-takers who are never afraid of failing. Is this true?

Shyam: Ha ha, no of course it's not true! Most people believe that entrepreneurs need to be fearlessly enthusiastic. But the truth is, fear is a very normal and valid human reaction, especially when you are planning to start your own business! In fact, my biggest fear was the fear of failing. The reality is, entrepreneurs fail as much as they succeed. The trick is to not allow the fear of failing to stop you from going ahead with your plans. Remember, failures are lessons for future success!

Interviewer: What, according to you, is the reason that entrepreneurs fail?

Shyam: Well, there is no one single reason why entrepreneurs fail. An entrepreneur can fail due to numerous reasons. You could fail because you have allowed your fear of failure to defeat you. You could fail because you are unwilling to delegate (distribute) work. As the saying goes, "You can do anything, but not everything!" You could fail because you gave up too easily – maybe you were not persistent enough. You could fail because you were focusing your energy on small, insignificant tasks and ignoring the tasks that were most important. Other reasons for failing are partnering with the wrong people, not being able to sell your product to the right customers at the right time at the right price... and many more reasons!

Interviewer: As an entrepreneur, how do you feel failure should be looked at?

Shyam: I believe we should all look at failure as an asset, rather than as something negative. The way I see it, if you have an idea, you should try to make it work, even if there is a chance that you will fail. That's because not trying is failure right there, anyway! And failure is not the worst thing that can happen. I think having regrets because of not trying, and wondering 'what if' is far worse than trying and actually failing.

Interviewer: How did you feel when you failed for the first time?

Shyam: I was completely heartbroken! It was a very painful experience. But the good news is, you do recover from the failure. And with every subsequent failure, the recovery process gets a lot easier. That's because you start to see each failure more as a lesson that will eventually help you succeed, rather than as an obstacle that you cannot overcome. You will start to realize that failure has many benefits.

Interviewer: Can you tell us about some of the benefits of failing?

Shyam: One of the benefits that I have experienced personally from failing is that the failure made me see things in a new light. It gave me answers that I didn't have before. Failure can make you a lot stronger. It also helps keep your ego in control.

Interviewer: What advice would you give entrepreneurs who are about to start their own enterprises?

Shyam: I would tell them to do their research and ensure that their product is something that is actually wanted by customers. I'd tell them to pick their partners and employees very wisely and cautiously. I'd tell them that it's very important to be aggressive – push and market your product as aggressively as possible. I would warn them that starting an enterprise is very expensive and that they should be prepared for a situation where they run out of money.

I would tell them to create long term goals and put a plan in action to achieve that goal. I would tell them to build a product that is truly unique. Be very careful and ensure that you are not copying another startup. Lastly, I'd tell them that it's very important that they find the right investors.

Interviewer: That's some really helpful advice, Shyam! I'm sure this will help all entrepreneurs to be more prepared before they begin their journey! Thank you for all your insight!

Tips



- Remember that nothing is impossible.
- Identify your mission and your purpose before you start.
- Plan your next steps – don't make decisions hastily.

UNIT 5.6: Preparing to be an Entrepreneur

Unit Objectives



By the end of this unit, participants will be able to:

1. Discuss how market research is carried out
2. Describe the 4 Ps of marketing
3. Discuss the importance of idea generation
4. Recall basic business terminology
5. Discuss the need for CRM
6. Discuss the benefits of CRM
7. Discuss the need for networking
8. Discuss the benefits of networking
9. Understand the importance of setting goals
10. Differentiate between short-term, medium-term and long-term goals
11. Discuss how to write a business plan
12. Explain the financial planning process
13. Discuss ways to manage your risk
14. Describe the procedure and formalities for applying for bank finance
15. Discuss how to manage your own enterprise
16. List important questions that every entrepreneur should ask before starting an enterprise

5.6.1 Market Study / The 4 Ps of Marketing / Importance of an IDEA: Understanding Market Research

Market research is the process of gathering, analyzing and interpreting market information on a product or service that is being sold in that market. It also includes information on:

- Past, present and prospective customers
- Customer characteristics and spending habits
- The location and needs of the target market
- The overall industry
- Relevant competitors

Market research involves two types of data:

- Primary information. This is research collected by yourself or by someone hired by you.
- Secondary information. This is research that already exists and is out there for you to find and use.

Primary research

Primary research can be of two types:

- Exploratory: This is open-ended and usually involves detailed, unstructured interviews.
- Specific: This is precise and involves structured, formal interviews. Conducting specific research is the more expensive than conducting exploratory research.

Secondary research

Secondary research uses outside information. Some common secondary sources are:

- Public sources: These are usually free and have a lot of good information. Examples are government departments, business departments of public libraries etc.
- Commercial sources: These offer valuable information but usually require a fee to be paid. Examples are research and trade associations, banks and other financial institutions etc.
- Educational institutions: These offer a wealth of information. Examples are colleges, universities, technical institutes etc.

The 4 Ps of Marketing

The 4 Ps of marketing are Product, Price, Promotion and Place. Let's look at each of these 4 Ps in detail.

Product

A product can be:

- A tangible good
- An intangible service

Whatever your product is, it is critical that you have a clear understanding of what you are offering, and what its unique characteristics are, before you begin with the marketing process.

Some questions to ask yourself are:

- What does the customer want from the product/service?
- What needs does it satisfy?
- Are there any more features that can be added?
- Does it have any expensive and unnecessary features?
- How will customers use it?
- What should it be called?
- How is it different from similar products?
- How much will it cost to produce?
- Can it be sold at a profit?

Price

Once all the elements of Product have been established, the Price factor needs to be considered. The Price of a Product will depend on several factors such as profit margins, supply, demand and the marketing strategy.

Some questions to ask yourself are:

- What is the value of the product/service to customers?
- Do local products/services have established price points?
- Is the customer price sensitive?
- Should discounts be offered?
- How is your price compared to that of your competitors?

Promotion

Once you are certain about your Product and your Price, the next step is to look at ways to promote it. Some key elements of promotion are advertising, public relations, social media marketing, email marketing, search engine marketing, video marketing and more.

Some questions to ask yourself are:

- Where should you promote your product or service?
- What is the best medium to use to reach your target audience?
- When would be the best time to promote your product?
- How are your competitors promoting their products?

Place

According to most marketers, the basis of marketing is about offering the right product, at the right price, at the right place, at the right time. For this reason, selecting the best possible location is critical for converting prospective clients into actual clients.

Some questions to ask yourself are:

- Will your product or service be looked for in a physical store, online or both?
- What should you do to access the most appropriate distribution channels?
- Will you require a sales force?
- Where are your competitors offering their products or services?
- Should you follow in your competitors' footsteps?
- Should you do something different from your competitors?

Importance of an IDEA

Ideas are the foundation of progress. An idea can be small or ground-breaking, easy to accomplish or extremely complicated to implement. Whatever the case, the fact that it is an idea gives it merit. Without ideas, nothing is possible. Most people are afraid to speak out their ideas, out for fear of being ridiculed. However, if are an entrepreneur and want to remain competitive and innovative, you need to bring your ideas out into the light.

Some ways to do this are by:

- Establishing a culture of brainstorming where you invite all interested parties to contribute
- Discussing ideas out loud so that people can add their ideas, views, opinions to them
- Being open minded and not limiting your ideas, even if the idea who have seems ridiculous
- Not discarding ideas that you don't work on immediately, but instead making a note of them and shelving them so they can be revisited at a later date

Tips



- Keep in mind that good ideas do not always have to be unique.
- Remember that timing plays a huge role in determining the success of your idea.
- Situations and circumstances will always change, so be flexible and adapt your idea accordingly.

5.6.2 Business Entity Concepts:

Basic Business Terminology

If your aim is to start and run a business, it is crucial that you have a good understanding of basic business terms. Every entrepreneur should be well versed in the following terms:

- **Accounting:** A systematic method of recording and reporting financial transactions.
- **Accounts payable:** Money owed by a company to its creditors.
- **Accounts Receivable:** The amount a company is owed by its clients.
- **Assets:** The value of everything a company owns and uses to conduct its business.
- **Balance Sheet:** A snapshot of a company's assets, liabilities and owner's equity at a given moment.
- **Bottom Line:** The total amount a business has earned or lost at the end of a month.
- **Business:** An organization that operates with the aim of making a profit.
- **Business to Business (B2B):** A business that sells goods or services to another business.
- **Business to Consumer (B2C):** A business that sells goods or services directly to the end user.
- **Capital:** The money a business has in its accounts, assets and investments. The two main types of capital are debt and equity.
- **Cash Flow:** The overall movement of funds through a business each month, including income and expenses.
- **Cash Flow Statement:** A statement showing the money that entered and exited a business during a specific period of time.
- **Contract:** A formal agreement to do work for pay.
- **Depreciation:** The degrading value of an asset over time.
- **Expense:** The costs that a business incurs through its operations.
- **Finance:** The management and allocation of money and other assets.
- **Financial Report:** A comprehensive account of a business' transactions and expenses.
- **Fixed Cost:** A one-time expense.
- **Income Statement (Profit and Loss Statement):** Shows the profitability of a business during a period of time.
- **Liabilities:** The value of what a business owes to someone else.
- **Marketing:** The process of promoting, selling and distributing a product or service.
- **Net Income/Profit:** Revenues minus expenses.
- **Net Worth:** The total value of a business.
- **Payback Period:** The amount of time it takes to recover the initial investment of a business.
- **Profit Margin:** The ratio of profit, divided by revenue, displayed as a percentage.
- **Return on Investment (ROI):** The amount of money a business gets as return from an investment.

- Revenue: The total amount of income before expenses are subtracted.
- Sales Prospect: A potential customer.
- Supplier: A provider of supplies to a business.
- Target Market: A specific group of customers at which a company's products and services are aimed.
- Valuation: An estimate of the overall worth of the business.
- Variable Cost: Expenses that change in proportion to the activity of a business.
- Working Capital: Calculated as current assets minus current liabilities.

5.6.3 CRM & Networking: What is CRM?

CRM stands for Customer Relationship Management. Originally the expression Customer Relationship Management meant managing one's relationship with customers. However, today it refers to IT systems and software designed to help companies manage their relationships.

The Need for CRM

The better a company can manage its relationships with its customers, the higher the chances of the company's success. For any entrepreneur, the ability to successfully retain existing customers and expand the enterprise is paramount. This is why IT systems that focus on addressing the problems of dealing with customers on a daily basis are becoming more and more in demand.

Customer needs change over time, and technology can make it easier to understand what customers really want. This insight helps companies to be more responsive to the needs of their customers. It enables them to modify their business operations when required, so that their customers are always served in the best manner possible. Simply put, CRM helps companies recognize the value of their clients and enables them to capitalize on improved customer relations.

Benefits of CRM

CRM has a number of important benefits:

- It helps improve relations with existing customers which can lead to:
 - Increased sales
 - Identification of customer needs
 - Cross-selling of products
- It results in better marketing of one's products or services
- It enhances customer satisfaction and retention
- It improves profitability by identifying and focusing on the most profitable customers

5.6.4 What is Networking?

In business, networking means leveraging your business and personal connections in order to bring in a regular supply of new business. This marketing method is effective as well as low cost. It is a great way to develop sales opportunities and contacts. Networking can be based on referrals and introductions, or can take place via phone, email, and social and business networking websites.

5.6.5 The Need for Networking

Networking is an essential personal skill for business people, but it is even more important for entrepreneurs. The process of networking has its roots in relationship building. Networking results in greater communication and a stronger presence in the entrepreneurial ecosystem. This helps build strong relationships with other entrepreneurs.

Business networking events held across the globe play a huge role in connecting like-minded entrepreneurs who share the same fundamental beliefs in communication, exchanging ideas and converting ideas into realities. Such networking events also play a crucial role in connecting entrepreneurs with potential investors. Entrepreneurs may have vastly different experiences and backgrounds but they all have a common goal in mind – they all seek connection, inspiration, advice, opportunities and mentors. Networking offers them a platform to do just that.

Benefits of Networking

Networking offers numerous benefits for entrepreneurs. Some of the major benefits are:

- Getting high quality leads
- Increased business opportunities
- Good source of relevant connections
- Advice from like-minded entrepreneurs
- Gaining visibility and raising your profile
- Meeting positive and enthusiastic people
- Increased self-confidence
- Satisfaction from helping others
- Building strong and lasting friendships

Tips



- Use social media interactions to identify needs and gather feedback.
- When networking, ask open-ended questions rather than yes/no type questions.

5.6.6 Business Plan: Why Set Goals

Setting goals is important because it gives you long-term vision and short-term motivation. Goals can be short term, medium term and long term.

Short-Term Goals

- These are specific goals for the immediate future.

Example: Repairing a machine that has failed.

Medium-Term Goals

- These goals are built on your short term goals.
- They do not need to be as specific as your short term goals.

Example: Arranging for a service contract to ensure that your machines don't fail again.

Long-Term Goals

These goals require time and planning.

They usually take a year or more to achieve.

Example: Planning your expenses so you can buy new machinery

Why Create a Business Plan

A business plan is a tool for understanding how your business is put together. It can be used to monitor progress, foster accountability and control the fate of the business. It usually offers a 3-5 year projection and outlines the plan that the company intends to follow to grow its revenues. A business plan is also a very important tool for getting the interest of key employees or future investors.

A business plan typically comprises of eight elements.

Elements of a Business Plan

Executive Summary

The executive summary follows the title page. The summary should clearly state your desires as the business owner in a short and businesslike way. It is an overview of your business and your plans. Ideally this should not be more than 1-2 pages.

Your Executive Summary should include:

- The Mission Statement: Explain what your business is all about.

Example: Nike's Mission Statement

Nike's mission statement is "To bring inspiration and innovation to every athlete in the world."

- Company Information: Provide information like when your business was formed, the names and roles of the founders, the number of employees, your business location(s) etc.
- Growth Highlights: Mention examples of company growth. Use graphs and charts where possible.
- Your Products/Services: Describe the products or services provided.
- Financial Information: Provide details on current bank and investors.
- Summarize future plans: Describe where you see your business in the future.

Business Description

The second section of your business plan needs to provide a detailed review of the different elements of your business. This will help potential investors to correctly understand your business goal and the uniqueness of your offering.

Your Business Description should include:

- A description of the nature of your business
- The market needs that you are aiming to satisfy
- The ways in which your products and services meet these needs
- The specific consumers and organizations that you intend to serve
- Your specific competitive advantages

Market Analysis

The market analysis section usually follows the business description. The aim of this section is to showcase your industry and market knowledge. This is also the section where you should lay down your research findings and conclusions.

Your Market Analysis should include:

- Your industry description and outlook
- Information on your target market
- The needs and demographics of your target audience
- The size of your target market
- The amount of market share you want to capture
- Your pricing structure
- Your competitive analysis
- Any regulatory requirements

Organization & Management

This section should come immediately after the Market Analysis.

Your Organization & Management section should include:

- Your company's organizational structure
- Details of your company's ownership
- Details of your management team
- Qualifications of your board of directors
- Detailed descriptions of each division/department and its function
- The salary and benefits package that you offer your people
- The incentives that you offer

Service or Product Line

The next section is the service or product line section. This is where you describe your service or product, and stress on their benefits to potential and current customers. Explain in detail why your product of choice will fulfill the needs of your target audience.

Your Service or Product Line section should include:

- A description of your product/service
- A description of your product or service's life cycle
- A list of any copyright or patent filings
- A description of any R&D activities that you are involved in or planning

Marketing & Sales

Once the Service or Product Line section of your plan has been completed, you should start on the description of the marketing and sales management strategy for your business.

Your Marketing section should include the following strategies:

- **Market penetration strategy:** This strategy focuses on selling your existing products or services in existing markets, in order to increase your market share.
- **Growth strategy:** This strategy focuses on increasing the amount of market share, even if it reduces earnings in the short-term.
- **Channels of distribution strategy:** These can be wholesalers, retailers, distributors and even the internet.
- **Communication strategy:** These can be written strategies (e-mail, text, chat), oral strategies (phone calls, video chats, face-to-face conversations), non-verbal strategies (body language, facial expressions, tone of voice) and visual strategies (signs, webpages, illustrations).

Your Sales section should include the following information:

- **A salesforce strategy:** This strategy focuses on increasing the revenue of the enterprise.
- **A breakdown of your sales activities:** This means detailing out how you intend to sell your products or services – will you sell it offline or online, how many units do you intend to sell, what price do you plan to sell each unit at, etc.

Funding Request

This section is specifically for those who require funding for their venture.

The Funding Request section should include the following information:

- How much funding you currently require.
- How much funding you will require over the next five years. This will depend on your long-term goals.
- The type of funding you want and how you plan to use it. Do you want funding that can be used only for a specific purpose, or funding that can be used for any kind of requirement?
- Strategic plans for the future. This will involve detailing out your long-term plans – what these plans are and how much money you will require to put these plans in motions.
- Historical and prospective financial information. This can be done by creating and maintaining all your financial records, right from the moment your enterprise started, to the present day. Documents required for this are your balance sheet which contains details of your company's assets and liabilities, your income statement which lists your company's revenues, expenses and net income for the year, your tax returns (usually for the last three years) and your cash flow budget which lists the cash that came in, the cash that went out and states whether you had a cash deficit (negative balance) or surplus (positive balance) at the end of each month.

Financial Planning

Before you begin building your enterprise, you need to plan your finances. Take a look at the steps for financial planning:

Step 1: Create a financial plan. This should include your goals, strategies and timelines for accomplishing these goals.

Step 2: Organize all your important financial documents. Maintain a file to hold your investment details, bank statements, tax papers, credit card bills, insurance papers and any other financial records.

Step 3: Calculate your net worth. This means figure out what you own (assets like your house, bank accounts, investments etc.), and then subtract what you owe (liabilities like loans, pending credit card amounts etc.) the amount you are left with is your net worth.

Step 4: Make a spending plan. This means write down in detail where your money will come from, and where it will go.

Step 5: Build an emergency fund. A good emergency fund contains enough money to cover at least 6 months' worth of expenses.

Step 6: Set up your insurance. Insurance provides long term financial security and protects you against risk.

Risk Management

As an entrepreneur, it is critical that you evaluate the risks involved with the type of enterprise that you want to start, before you begin setting up your company. Once you have identified potential risks, you can take steps to reduce them. Some ways to manage risks are:

- Research similar business and find out about their risks and how they were minimized.
- Evaluate current market trends and find out if similar products or services that launched a while ago are still being well received by the public.
- Think about whether you really have the required expertise to launch your product or service.
- Examine your finances and see if you have enough income to start your enterprise.
- Be aware of the current state of the economy, consider how the economy may change over time, and think about how your enterprise will be affected by any of those changes.
- Create a detailed business plan.

Tips



- Ensure all the important elements are covered in your plan.
- Scrutinize the numbers thoroughly.
- Be concise and realistic.
- Be conservative in your approach and your projections.
- Use visuals like charts, graphs and images wherever possible.

5.6.7 Procedure and Formalities for Bank Finance:

The Need for Bank Finance

For entrepreneurs, one of the most difficult challenges faced involves securing funds for startups. With numerous funding options available, entrepreneurs need to take a close look at which funding methodology works best for them. In India, banks are one of the largest funders of startups, offering funding to thousands of startups every year.

What Information Should Entrepreneurs Offer Banks for Funding?

When approaching a bank, entrepreneurs must have a clear idea of the different criteria that banks use to screen, rate and process loan applications. Entrepreneurs must also be aware of the importance of providing banks with accurate and correct information. It is now easier than ever for financial institutions to track any default behaviour of loan applicants. Entrepreneurs looking for funding from banks must provide banks with information relating to their general credentials, financial situation and guarantees or collaterals that can be offered.

General Credentials

This is where you, as an entrepreneur, provide the bank with background information on yourself. Such information includes:

- Letter(s) of Introduction: This letter should be written by a respected business person who knows you well enough to introduce you. The aim of this letter is set across your achievements and vouch for your character and integrity.
- Your Profile: This is basically your resume. You need to give the bank a good idea of your educational achievements, professional training, qualifications, employment record and achievements.
- Business Brochure: A business brochure typically provides information on company products, clients, how long the business has been running for etc.
- Bank and Other References: If you have an account with another bank, providing those bank references is a good idea.
- Proof of Company Ownership or Registration: In some cases, you may need to provide the bank with proof of company ownership and registration. A list of assets and liabilities may also be required.

Financial Situation

Banks will expect current financial information on your enterprise. The standard financial reports you should be prepared with are:

- Balance Sheet
- Cash-Flow Statement
- Business Plan
- Profit-and-Loss Account
- Projected Sales and Revenues
- Feasibility Study

Guarantees or Collaterals

Usually banks will refuse to grant you a loan without security. You can offer assets which the bank can seize and sell off if you do not repay the loan. Fixed assets like machinery, equipment, vehicles etc. are also considered to be security for loans.

The Lending Criteria of Banks

Your request for funding will have a higher chance of success if you can satisfy the following lending criteria:

- Good cash flow
- Adequate shareholders' funds
- Adequate security
- Experience in business
- Good reputation

The Procedure

To apply for funding the following procedure will need to be followed.

1. Submit your application form and all other required documents to the bank.
2. The bank will carefully assess your credit worthiness and assign ratings by analyzing your business information with respect to parameters like management, financial, operational and industry information as well as past loan performance.
3. The bank will make a decision as to whether or not you should be given funding.

Tips



- Get advice on funding options from experienced bankers.
- Be cautious and avoid borrowing more than you need, for longer than you need, at an interest rate that is higher than you are comfortable with.

5.6.8 Enterprise Management - An Overview: How to Manage Your Enterprise

To manage your enterprise effectively you need to look at many different aspects, right from managing the day-to-day activities to figuring out how to handle a large scale event. Let's take a look at some simple steps to manage your company effectively.

Step 1: Use your leadership skills and ask for advice when required.

Let's take the example of Ramu, an entrepreneur who has recently started his own enterprise. Ramu has good leadership skills – he is honest, communicates well, knows how to delegate work etc. These leadership skills definitely help Ramu in the management of his enterprise. However, sometimes Ramu comes across situations that he is unsure how to handle. What should Ramu do in this case? One solution is for him to find a more experienced manager who is willing to mentor him. Another solution is for Ramu to use his networking skills so that he can connect with managers from other organizations, who can give him advice on how to handle such situations.

Step 2: Divide your work amongst others – realize that you cannot handle everything yourself.

Even the most skilled manager in the world will not be able to manage every single task that an enterprise will demand of him. A smart manager needs to realize that the key to managing his enterprise lies in his dividing all his work between those around him. This is known as delegation. However, delegating is not enough. A manager must delegate effectively if he wants to see results. This is important because delegating, when done incorrectly, can result in you creating even more work for yourself. To delegate effectively, you can start by making two lists. One list should contain the things that you know you need to handle yourself. The second list should contain the things that you are confident can be given to others to manage and handle. Besides incorrect delegation, another issue that may arise is over-delegation. This means giving away too many of your tasks to others. The problem with this is, the more tasks you delegate, the more time you will spend tracking and monitoring the work progress of those you have handed the tasks to. This will leave you with very little time to finish your own work.

Step 3: Hire the right people for the job.

Hiring the right people goes a long way towards effectively managing your enterprise. To hire the best people suited for the job, you need to be very careful with your interview process. You should ask potential candidates the right questions and evaluate their answers carefully. Carrying out background checks is always a good practice. Running a credit check is also a good idea, especially if the people you are planning to hire will be handling your money. Create a detailed job description for each role that you want filled and ensure that all candidates have a clear and correct understanding of the job description. You should also have an employee manual in place, where you

put down every expectation that you have from your employees. All these actions will help ensure that the right people are approached for running your enterprise.

Step 4: Motivate your employees and train them well.

Your enterprise can only be managed effectively if your employees are motivated to work hard for your enterprise. Part of being motivated involves your employees believing in the vision and mission of your enterprise and genuinely wanting to make efforts towards pursuing the same. You can motivate your employees with recognition, bonuses and rewards for achievements. You can also motivate them by telling them about how their efforts have led to the company's success. This will help them feel pride and give them a sense of responsibility that will increase their motivation.

Besides motivating your people, your employees should be constantly trained in new practices and technologies. Remember, training is not a one-time effort. It is a consistent effort that needs to be carried out regularly.

Step 5: Train your people to handle your customers well.

Your employees need to be well-versed in the art of customer management. This means they should be able to understand what their customers want, and also know how to satisfy their needs. For them to truly understand this, they need to see how you deal effectively with customers. This is called leading by example. Show them how you sincerely listen to your clients and the efforts that you put into understand their requirements. Let them listen to the type of questions that you ask your clients so they understand which questions are appropriate.

Step 6: Market your enterprise effectively.

Use all your skills and the skills of your employees to market your enterprise in an effective manner. You can also hire a marketing agency if you feel you need help in this area.

Now that you know what is required to run your enterprise effectively, put these steps into play, and see how much easier managing your enterprise becomes!

Tips 

- Get advice on funding options from experienced bankers.
- Be cautious and avoid borrowing more than you need, for longer than you need, at an interest rate that is higher than you are comfortable with.

5.6.9. 20 Questions to Ask Yourself Before Considering Entrepreneurship

1. Why am I starting a business?
2. What problem am I solving?
3. Have others attempted to solve this problem before? Did they succeed or fail?
4. Do I have a mentor¹ or industry expert that I can call on?
5. Who is my ideal customer²?
6. Who are my competitors³?
7. What makes my business idea different from other business ideas?
8. What are the key features of my product or service?
9. Have I done a SWOT⁴ analysis?
10. What is the size of the market that will buy my product or service?
11. What would it take to build a minimum viable product⁵ to test the market?
12. How much money do I need to get started?
13. Will I need to get a loan?
14. How soon will my products or services be available?
15. When will I break even⁶ or make a profit?
16. How will those who invest in my idea make a profit?
17. How should I set up the legal structure⁷ of my business?
18. What taxes⁸ will I need to pay?
19. What kind of insurance⁹ will I need?
20. Have I reached out to potential customers for feedback?

Tips



- It is very important to validate your business ideas before you invest significant time, money and resources into it.
- The more questions you ask yourself, the more prepared you will be to handle the highs and lows of starting an enterprise.

Footnotes:

1. A mentor is a trusted and experienced person who is willing to coach and guide you.
2. A customer is someone who buys goods and/or services.
3. A competitor is a person or company that sells products and/or services similar to your products and/or services.
4. SWOT stands for Strengths, Weaknesses, Opportunities and Threats. To conduct a SWOT analysis of your company, you need to list down all the strengths and weaknesses of your company, the opportunities that are present for your company and the threats faced by your company.

5. A minimum viable product is a product that has the fewest possible features, that can be sold to customers, for the purpose of getting feedback from customers on the product.
6. A company is said to break even when the profits of the company are equal to the costs.
7. The legal structure could be a sole proprietorship, partnership or limited liability partnership.
8. There are two types of taxes – direct taxes payable by a person or a company, or indirect taxes charged on goods and/or services.
9. There are two types of insurance – life insurance and general insurance. Life insurance covers human life while general insurance covers assets like animals, goods, cars etc.

Notes



A large rectangular area with a thin orange border, containing 25 horizontal lines for writing notes.



Skill India
कौशल भारत - कुशल भारत



सत्यमेव जयते
GOVERNMENT OF INDIA
MINISTRY OF SKILL DEVELOPMENT
& ENTREPRENEURSHIP



N.S.D.C.
National
Skill Development
Corporation

Transforming the skill landscape



Skilling India in Electronics

Address: 155, 2nd Floor, ESC House, Okhla Industrial Area,
Phase 3, New Delhi- 110020, India

Email: info@essc-india.org

Web: www.essc-india.org

Phone: +91 8447738501

Price: ₹

